

Matchless Range of Applications in Concrete Paving

SLIPFORM PAVER SP 25 (i)



MATCHLESS RANGE OF APPLICATIONS IN CONCRETE PAVING

The multifunctional slipform paver paves a wide range of monolithic profiles up to a height of 2.0 m.

It can be used to pave concrete surfaces with widths of up to 3.5 m using both inset and offset methods (cannot be combined with all options).

One or two hydraulic parallelogram swing legs at the front and two hydraulically telescoping track units at the rear enable extremely flexible concrete paving.

The intelligent, electronic steering and control concept means the machine can be driven through very tight radii and offers exceptional adaptability to any situation on the construction site.

The machine can be precisely controlled via stringline scanning, without a stringline using WIRTGEN AutoPilot 2.0, or via 3D applications.



WIRTGEN SLIPFORM PAVERS

OFFSET SLIPFORM PAVERS

- > Offset paving width up to 4.0 m¹⁾
- > Offset paving height up to 3.0 m¹⁾

PLACER / SPREADERS

- > Inset paving width up to 12.0 m¹⁾
- > Inset layer thickness up to 500 mm¹⁾

INSET SLIPFORM PAVERS

- > Inset paving width up to 16.0 m¹⁾
- > Inset paving height up to 450 mm¹⁾

TEXTURE CURING MACHINES

- > Working width up to 18.0 m
- > Working height up to 500 mm

¹⁾ Special paving widths, paving thicknesses, paving heights, and other options available on request

OVERVIEW OF HIGHLIGHTS

Perfectly equipped

01 Fully Modular Inset Mold System

Modular design permits machine configuration in accordance with site conditions. Adjustable to different working widths. Special profile cross-sections can be implemented.

02 Highly Flexible Offset Mold System

Concrete feeding system offering a wide variety of adjustment options. Flexible arrangement of the offset mold on the left or right side, close to or far to one side of the machine frame. A wide variety of different offset molds for poured-in-place profiles is available for a wide range of applications.

03 High-Quality Machine Control System

High-quality machine control system for maximum operational reliability, precise machine functionality and automatic detection of configuration parameters and operating states.

04 Steering and Drive System Built to Field Requirements

An adaptive electronic steering and control system ensures precise driving behavior and high precision in concrete paving.

05 Efficient Diesel Engine Control

Engine management in accordance with performance requirements for low diesel consumption and lowest environmental emissions.



06 AutoPilot 2.0 - Cost-Efficient Stringless Machine Control System

Cost-efficient machine control system developed by WIRTGEN for high-precision stringless concrete paving.

07 Future-Proof 3D Interface

Certified standard interface for reliable communication with standard 3D systems.

08 Premium-Class Cross Slope Control System

Unmatched electronic cross slope control system developed in-house to ensure perfect paving results.

09 Modular Adaptability

Flexible arrangement of the paving mold and track units to ensure high machine utilization rates.

10 Ease of Operation

Ergonomically designed operator's platform with self-explanatory operating concept for maximum productivity.

11 Intelligent Transport Concept

Compact machine dimensions ensure ease of transport.



INSET CONCRETE PAVER DRIVES EFFICIENCY TO THE MAX

Wide Range of Slab Paving Widths

The compact SP 25(i) slipform paver is an exceptionally versatile multipurpose machine for high-quality concrete paving. In addition to a wide variety of different offset profiles, the SP 25(i) achieves perfection in paving narrow roads, agricultural roads and bicycle paths, channels and gutters of different sizes in inset application. The paver's modular design permits it to be fully tailored to various applications in accordance with specific requirements, allowing components to be retrofitted quite easily even many years later. There is no question about it: the SP 25(i) sets new standards in economic efficiency.

Further hallmarks include flexible positioning of the track units, spreading auger extension and the use of up to ten electric or hydraulic vibrators.

Intelligent electronic steering and control technology ensures full compliance with the specified requirements.

- 01 Flexible access to operator's platform
- 02 Telescoping machine frame
- 03 Pivoting legs for adjustment of the track units to site conditions
- 04 One or two hydraulically driven, separately height-adjustable and steerable front track units
- 05 Telescoping front section of machine frame
- 06 Spreading auger offering modular extension options
- 07 Slab paving mold
- 08 Two laterally telescoping rear track units
- 09 Lifting column with hydraulic cylinder for height adjustment
- 10 Power unit



- 01** Flexible positioning of the track units allows paving of a 3.0 m wide rural path.
- 02** The SP 25 (i) offers a comprehensive range of inset applications including the production of concrete slabs from 1.0 m to 3.5 m in width.

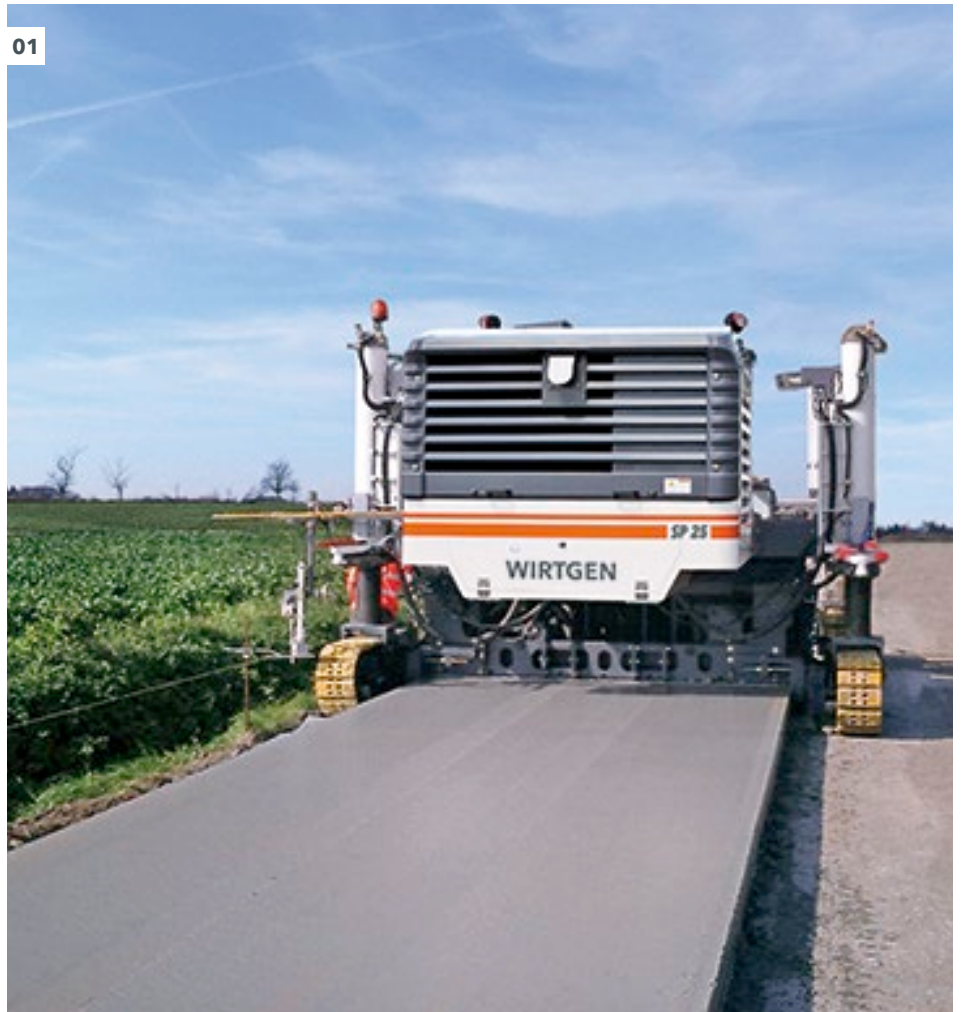
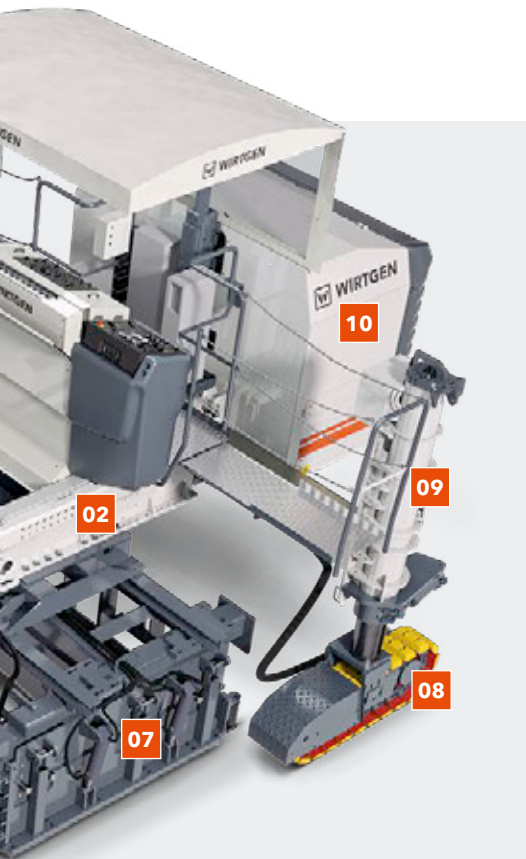

TREMENDOUS RANGE OF INSET PAVING APPLICATIONS

01



01 Paving a 3.5 m wide concrete road.

02 Highly precise paving of a 3.0 m wide embankment road using WIRTGEN AutoPilot 2.0.



The SP 25(i) in Action

The SP 25(i) is capable of paving concrete slabs at widths ranging from 1.0 m to 3.5 m and layer thicknesses of up to 400 mm in inset application. Flexible positioning of the paver's track units allows slab widths of 3.5 m to be achieved. Its modular design makes easy work of modifying the SP 25(i) for the different paving applications: the spreading auger, slab paving mold and other complementary features can be extended in increments. Special profiles and paving widths are available in

accordance with customer specifications. It is possible to connect up to ten electric or hydraulic vibrators.

The SP 25(i) is the ideal choice for completing special assignments both in the open and in tunnel construction – either with stringline or using the stringless WIRTGEN AutoPilot 2.0 or standard 3D systems. Molds can be changed or the SP 25(i) converted from inset to offset paving quickly right on the construction site.



03 Paving a concrete slab track.



04 Paving wheel tracks for an agricultural road.

05 Paving a slab track in a tunnel using a 3D control system in extremely restricted space conditions.



06 Producing a large water gutter.



OFFSET CONCRETE PAVER FOR COMPLEX APPLICATIONS

Unrivaled Flexibility

The SP 25(i) slipform paver truly excels when it comes to pouring small or large concrete profiles in offset application. Where other slipform pavers have given up on the job long ago, the SP 25(i) realizes its full potential: whether a profile needs to be poured across an existing profile or at a large distance or major difference in height between the machine frame and the paving site - these are the challenges that the SP 25(i) masters with the greatest ease. Exceptional flexibility in positioning the paving mold, track units and concrete feeding system enables it to fully adapt to virtually any paving situation. Offset paving molds can optionally be mounted on the left or right side of the slipform paver.

The paver's repertoire includes concrete safety barriers, kerbs, kerb and gutter profiles, channels, water gutters and narrow roads as well as a wide variety of special profiles.

- 01 Walk-through operator's platform offering a good view of both the machine and the construction site
- 02 Concrete feeding system in belt conveyor or auger conveyor design offering various adjustment options
- 03 Water tank with a capacity of 550 l
- 04 Receiving hopper for freshly delivered concrete
- 05 Offset mold, suitable for mounting on the left and right side of the paver, telescoping to both sides
- 06 Cross-feeding auger
- 07 Clearly structured control panel, suitable for mounting on the left or right side of the operator's platform
- 08 Service panel
- 09 Weather canopy



- 01** The SP 25(i) produces large poured-in-place off-set profiles at standard heights of up to 2.0 m or standard widths of up to 2.5 m.
- 02** The paver is at its best when pouring concrete safety barriers of up to 2.0 m in height.

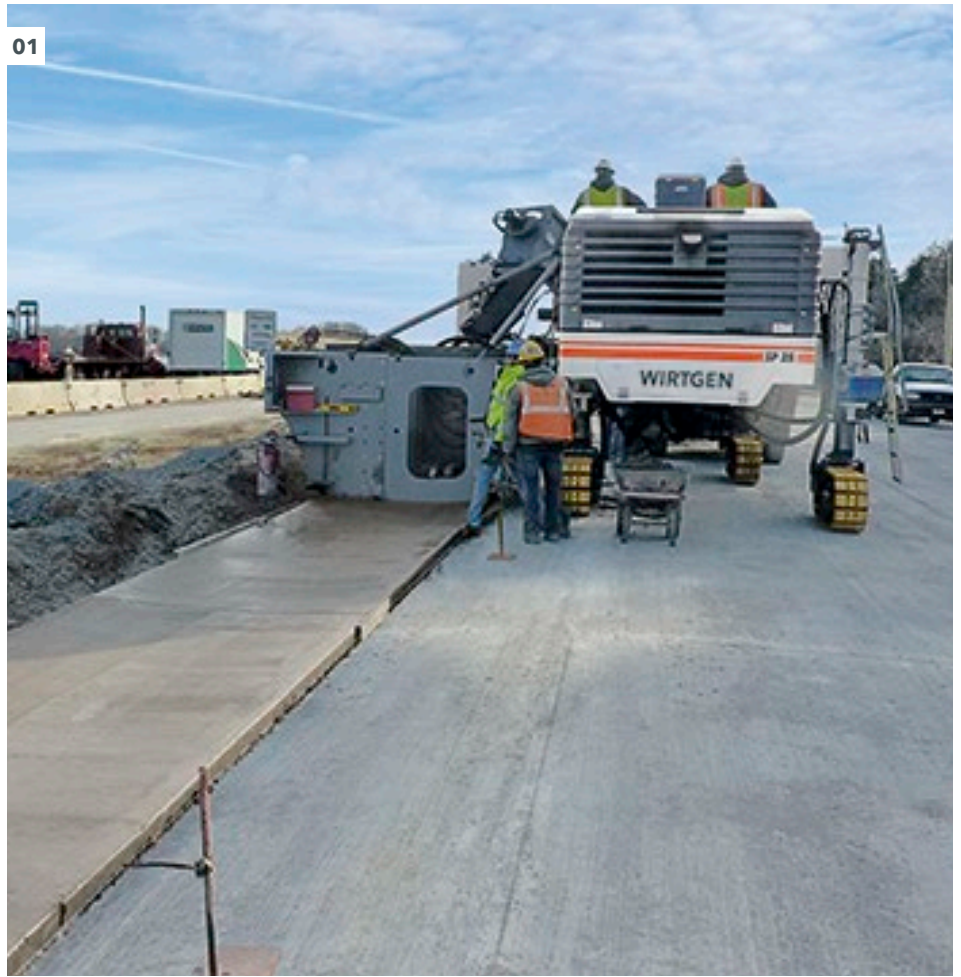

TREMENDOUS RANGE OF OFFSET PAVING APPLICATIONS



01

The SP 25 (i) in Action

The SP 25 (i) produces poured-in-place concrete profiles at standard heights of up to 2.0 m or standard widths of up to 2.5 m. Even larger profiles can be realized in accordance with customer specifications. The geometries of the offset mold and mold mount are irrelevant, as mature manufacturing processes enable us to translate virtually any customer requirement into viable, real-life solutions. Tried-and-tested standard offset molds can be supplied within an extremely short period of time. In addition, the WIRTGEN SP 25 (i) offers a unique selling proposition: the paving mold can be mounted on the left or right side of the paver.

Flexible positioning of the paving mold, track units and concrete feeding system tremendously increases the range of applications of the SP 25 (i). The paver's flexibility is enhanced even further by the telescoping mold mount and the modular addition of individual complementary features.



02

01 Paving a rainwater gutter along a slope with the mold mounted on the right side of the machine.

02 Paving a concrete safety barrier as central reservation.

03 Paving a rainwater gutter with the mold mounted on the left side of the machine.

04 Paving a 2.5 m wide bicycle path.

05 Paving a large special profile.

06 Paving a special profile on a farm.



03



04



05



06

RELAXED WORKING AND EASE OF OPERATION

Gaining Full Control Quickly

Everything on the operator's platform of the SP 25 (i) is arranged with clarity and ergonomic principles in mind. A state-of-the-art graphic screen is incorporated in the centre of the control panel: the multifunctional screen keeps the operator informed of all the relevant operating parameters on an event-driven basis. Operation of the paver via the screen is easy and promoted further by clear, language-independent labeling. The control panel can be mounted on the left or right to always ensure a perfect view of the entire paving process. A comprehensive lighting system is part of the paver's on-board equipment, permitting effi-

cient operation even in darkness. All of these features allow the operator to familiarize himself with the SP 25 (i) quickly, focus on his work and deliver top performance.

The weather canopy can be raised and lowered hydraulically even with the engine switched off and allows paving to continue regardless of weather conditions. Effective engine sound-proofing and anti-vibration mounted treads minimize the impact of machine vibrations on both the operator and the environment.

Always Where You Need It

Flexibly positionable Control Panel

Never Lose Sight of What's Going On

Optimal all-round vision

01





01 Additional synergistic effects are created by the standardized, intuitive operating concept of the entire range of WIRTGEN slip-form pavers.

02 The convenient access ladder can be adjusted in height manually and folded in for transport.

03 Control panel suitable for mounting on the left or right side for perfect visibility.

04 Perfect view of the paving process from the spacious, ergonomically designed operator's platform.

FAULTLESS OPERATION - WHATEVER THE JOB

Software and Hardware

The SP 25 (i) slipform paver features an integrated machine control system of the highest quality, in which the large proportion of software developed in-house plays the decisive role. For the constant further development of the software guarantees maximum operational reliability of the machine. In addition, our many years of experience in software and hardware development allow for higher and more flexible machine functionality in terms of applications and meeting specific customer requirements.

Efficient engine management is an integral part of the machine control system. WIDIAG, the diagnostic system with standardized interface, is used by WIRTGEN service engineers for quick, specific service diagnostics right on site. In addition, the WIRTGEN WITOS FleetView telematics system supports fleet management, machine position and status monitoring, as well as maintenance and diagnostic procedures. In short: it is yet another key driver for improved efficiency in day-to-day operation.

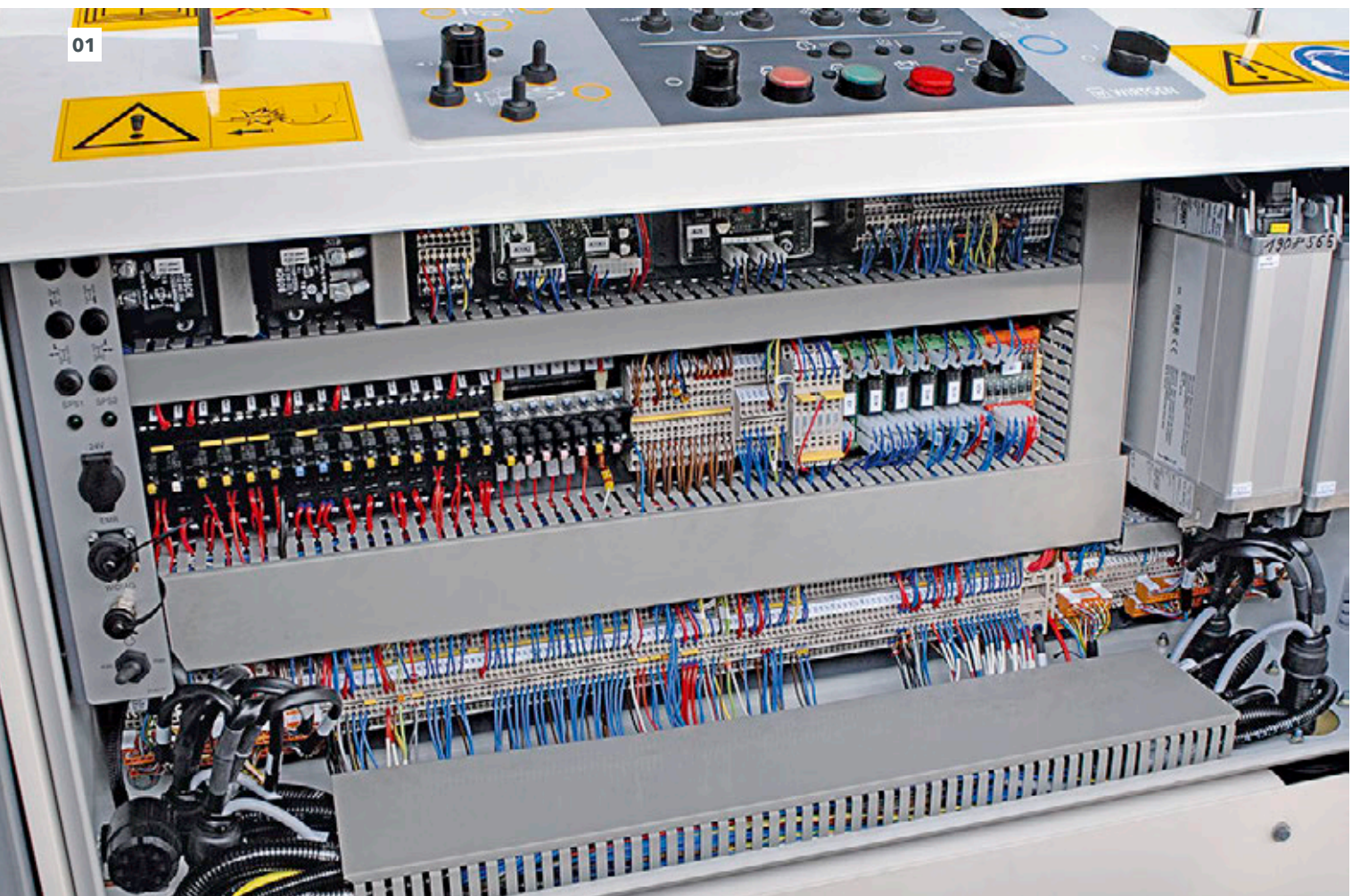

Application-Oriented Machine Control

In-house developed control software

Fit for the Future

WITOS FleetView onboard

- 01** Software developed in-house ensures high operational reliability.
- 02** Separate valves on the track units ensure high-precision height adjustment and steering control.

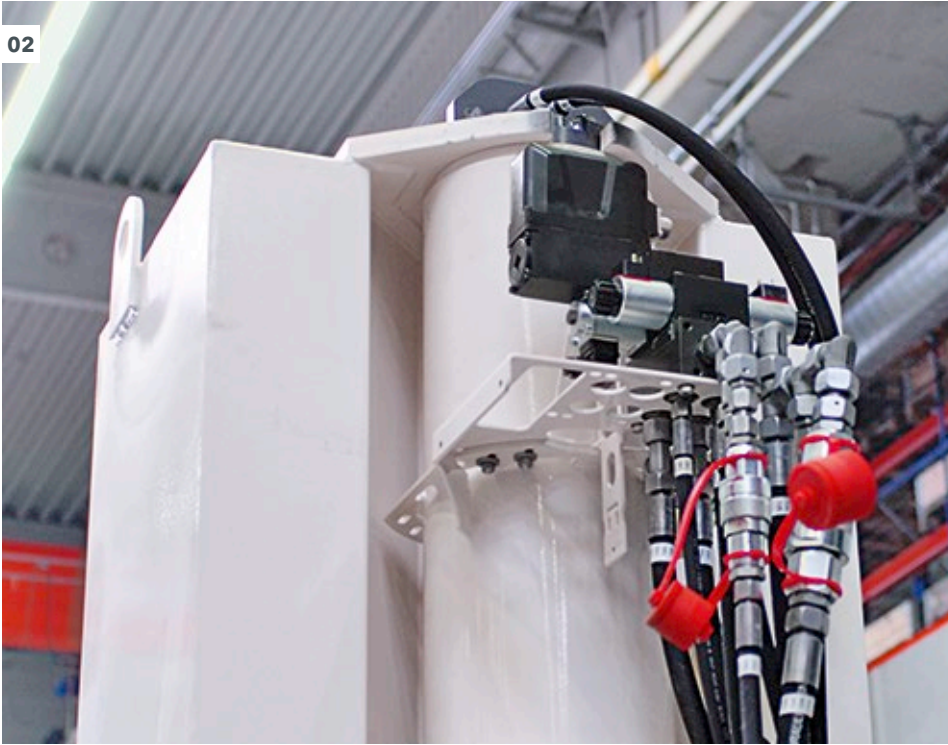

03 - 04 The high-quality machine control system guarantees perfect straight-ahead travel and precise steering in bends.

PRECISE DRIVING BEHAVIOR - WHATEVER THE JOB

Precision in Concrete Paving Guaranteed

The SP 25 (i) features an intelligent electronic steering and control system which offers everything it takes for precise driving behavior and therefore high-precision concrete paving. The slipform paver comes into its own especially when working in bends. This is where the tried-and-tested Ackermann steering system ensures precise driving behavior and therefore highest concrete quality. The computer-assisted steering system varies the speed of the individual track units during cornering, thus enabling the SP 25 (i) to follow the previously specified references with pinpoint accuracy. In addition, the steering angle position of each track unit is adjusted fully automatically based on the radius to be paved and the paver geometry. An unbeatable feature!

The SP 25 (i) is capable of producing profiles with a minimum radius of only 1.0 m. High-precision drive motor control guarantees smooth machine travel even when operating at extremely low speeds. The control system prevents spinning of the track units during cornering, maintaining optimum traction.

Additional steering modes - crab and coordinated - make easy work of repositioning and maneuvering the slipform paver.



Absolute Precision

Integrated Ackermann steering

No Problems in Corners

1.0-m paving radius

- 01** In stringless operation, the SP 25 (i) permits a paving radius of 1.0 mm - or less.
- 02** Control panel with different steering mode settings for maneuvering.
- 03** Automatic adjustment of the steering angle and speed of each track unit to the paver's geometry.

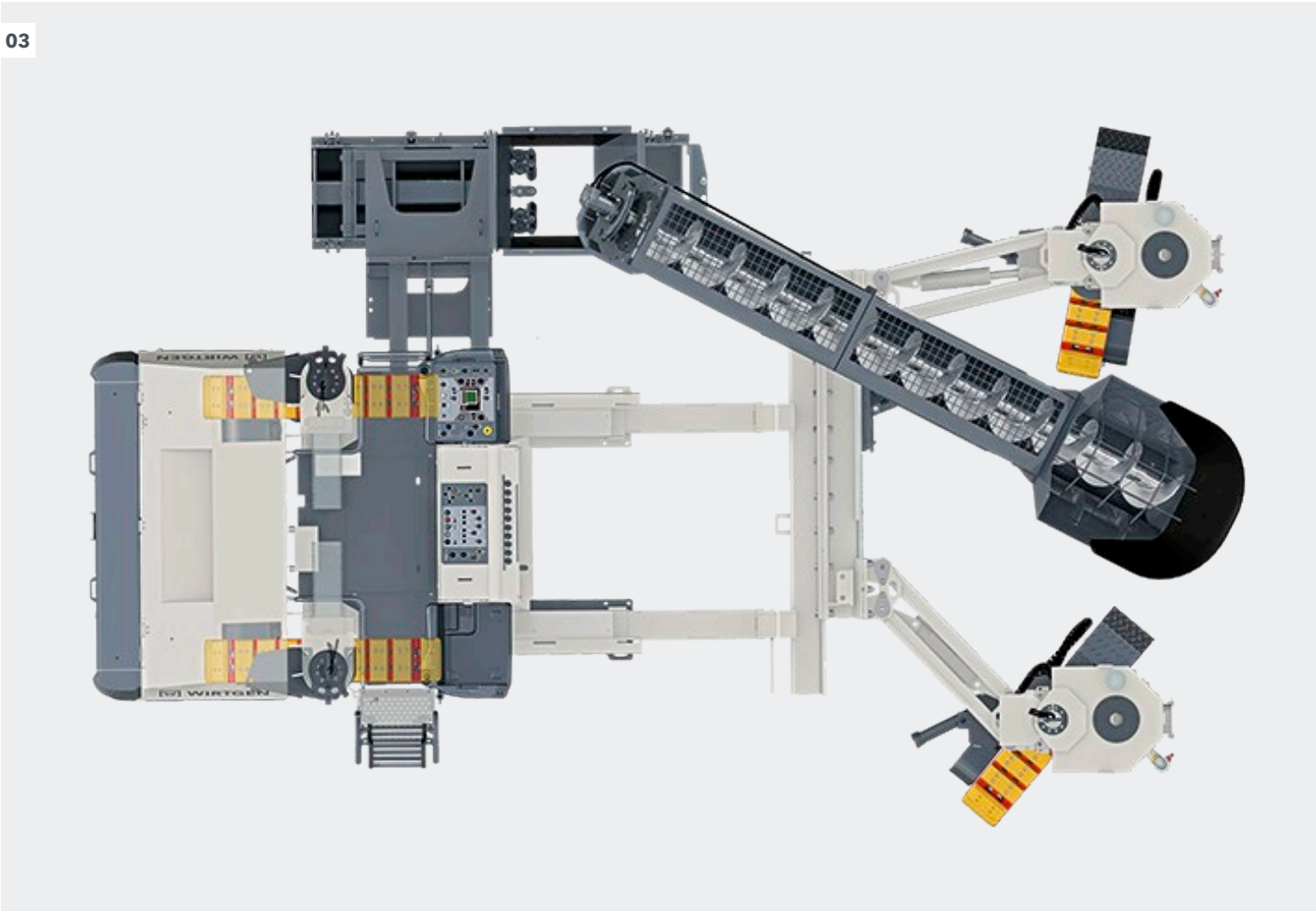

03

STATE-OF-THE-ART ENGINE TECHNOLOGY

Reduced Carbon Emissions, Lower Operating Costs

ECO-Mode engine control

01





Efficient Diesel Engine Control

Fuel consumption of the SP 25(i) is minimized by the integrated ECO mode diesel engine control system. Upon activation of the ECO mode system, the engine speed is adjusted to the paver's performance requirements in an automated process. The engine operates at low speeds, for example, to match low machine advance rates, and at higher speeds to match the machine's increasing travel speed. High or maximum engine speeds are only required at high machine advance rates or when operating vibrators or a trimmer. The ECO mode system detects the current paving situation and optimizes the engine speed in accordance with the machine features used without the need for manual operator intervention. The performance-based engine management system guarantees low diesel consumption, low noise emission levels and low operating costs.

The engine technology of the SP 25 complies with the specifications of exhaust emission standards EU Stage 3a / US EPA Tier 3. The SP 25 i features state-of-the-art engine technology for lowest environmental emission levels, complying with the strict specifications of exhaust emission standards EU Stage 5 / US EPA Tier 4f.

01 The ECO mode engine control system enables the SP 25(i) to always work in the optimum performance and torque ranges.

02 The ECO mode engine control system guarantees low fuel consumption.

03 Manual selection of the ECO mode system.



AUTOPILOT 2.0 - COST-EFFICIENT, STRINGLESS MACHINE CONTROL SYSTEM



Work More Effectively

The standard 3D machine control systems for producing poured-in-place concrete profiles by means of a slipform paver are frequently not a viable option especially for small contracting companies. This is mostly due to high investment costs, the level of technical support required in day-to-day operation, and the need to manage digital modelling data.

WIRTGEN provides customers with AutoPilot 2.0, an innovative and cost-efficient alternative system developed in-house, which eliminates these drawbacks. The system is based on GNSS (Global Navigation Satellite System) and has been precisely tailored for use with the SP 25(i), assisting with the auto-

mated paving of a wide variety of different offset and inset concrete profiles, such as safety barriers on motorways or kerbs for traffic islands.

It requires no more than the uninterrupted reception of signals from a sufficiently large number of satellites and proficient use of the system including the Field Rover prism pole. Relevant points of the object to be paved are taught-in via a tablet computer on the Field Rover using software developed in-house. These are then used to compute a virtual stringline which is optimized for the slipform paving process and incorporates local conditions.

Innovation and Efficient

AutoPilot 2.0 system developed in-house

Higher Speed, Fewer Pitfalls

Stringless concrete paving



Unlike with conventional 3D systems, the digital data model is created on the construction site. After connecting the tablet computer on the operator's platform of the paver, the specifications stored in the system can be executed immediately without requiring any intermediate steps. The operator remains in full control, however, and can intervene in the autonomous paving process whenever necessary. The system also permits the import of data, offering unique verification and intuitive editing functions.

Major advantage of the system: it dispenses with time-consuming surveying operations, the installation and removal of stringline, and the preparation of a geodetic data model.

01 Stringless paving of poured-in-place profiles using the AutoPilot 2.0 system.

02 The Field Rover is used to collect measuring points and perform check measurements.

03 Following the successful calculation and verification of the virtual stringline, the tablet computer is placed into the docking station on the slipform paver.

HIGH-PRECISION 3D CONTROL

01





Made-To-Measure Profile Paving

Stringless control systems will drive the future of professional concrete paving. In addition to ensuring high paving accuracy, 3D control systems offer yet another major advantage: establishing the digital terrain models is much more cost-effective than surveying and the installation of stringline. The SP 25(i) is all set for the job: an integrated standard interface enables it to be fitted with a state-of-the-art external 3D control system in lieu of AutoPilot 2.0.

In thorough acceptance procedures, we have tested the compatibility of the SP 25(i) with the 3D control systems of leading suppliers, thus ensuring safety of use. In addition, our own experts are working on continuously improving and perfecting the systems.

01 WIRTGEN-specific acceptance procedures ensure safe application of the different 3D control systems.

02 Field-proven integrated standard interface for 3D control systems.



Be Prepared

Integrated standard interface

UNRIVALED CROSS SLOPE CONTROL

Perfect Paving Quality

Perfect paving results are guaranteed by the electronic cross slope control system developed by WIRTGEN on the basis of the "Rapid Slope" sensor.

Optimized control technology enables the innovative cross slope control system to achieve as yet unmatched dynamics and precision. Significantly shorter machine response times are reflected in the precision and quality of the completed concrete product.

The WIRTGEN cross slope control system can be relied on to level out any vibrations or ground irregularities in virtually no time at all.

For Precise Results

RAPID SLOPE dynamic cross slope control

01



01 - 02 Cross slope specifications are adhered to with pinpoint precision.

02



MAXIMUM STABILITY IN ANY GIVEN SITUATION

Fully Modular Machine Design

Offering a fully modular machine design, ease of modification and the effortless addition of complementary features, the SP 25 (i) caters to all inset and offset paving applications. The machine frame can be telescoped in both longitudinal and transverse direction, and the paver's technical features allow reliable adjustment to any given site conditions.

The SP 25 (i) can be equipped with add-on components to offer solutions for complex, customer-specific paving requirements. In addition, standard interfaces even allow the slipform paver to be retrofitted with customer options.

Examples of machine setup options

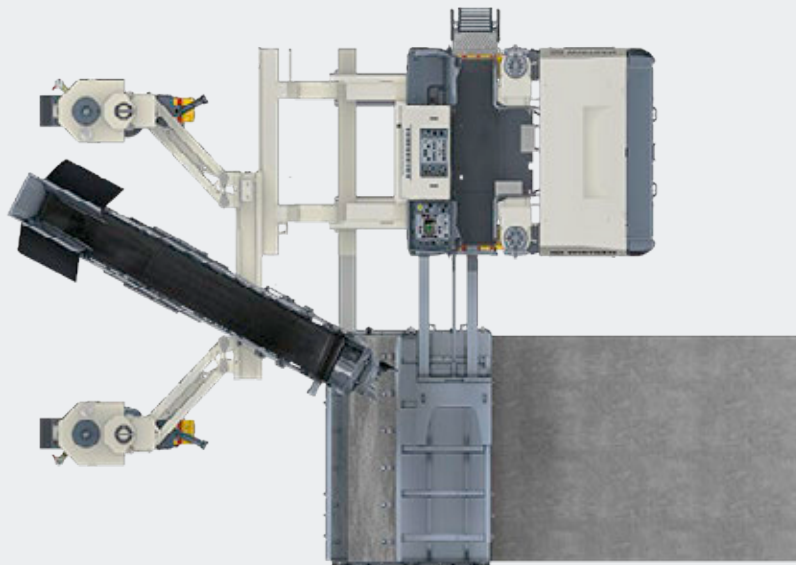
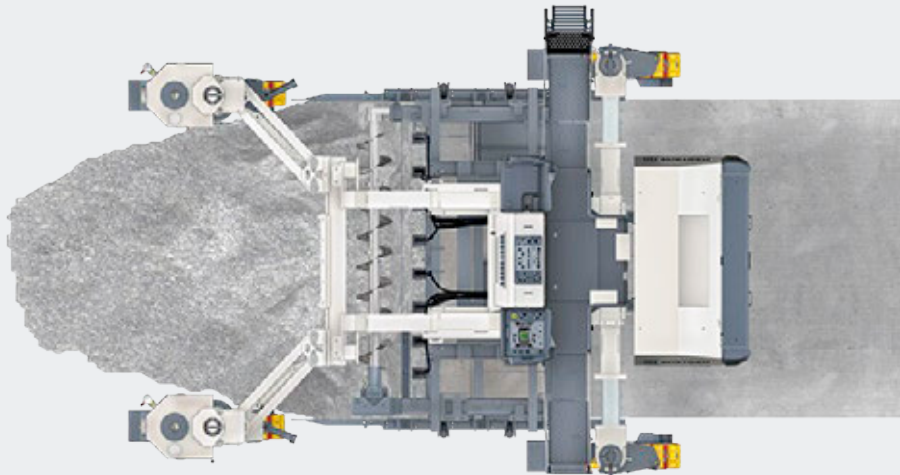

Flexible Reconfiguration as Required

Modular machine design concept

Masters Every On-Site Challenge

Variably positionable swing legs and track units

One or two front track units with large pivoting angles and laterally telescoping rear track units with extension elements offer maximum flexibility. The stability of the SP 25(i) can be increased even further by means of the telescoping front frame section with two pivoting track units.

The offset paving mold can be mounted on the left or right side of the machine, adjusted in height hydraulically and telescoped to either side. Numerous adjustment options for the different concrete feeding systems and an additional cross-feeding auger ensure flexibility in concrete feeding.

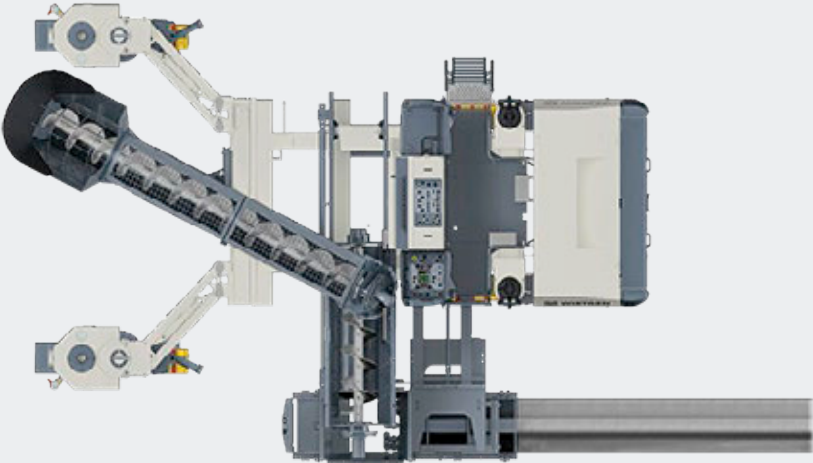
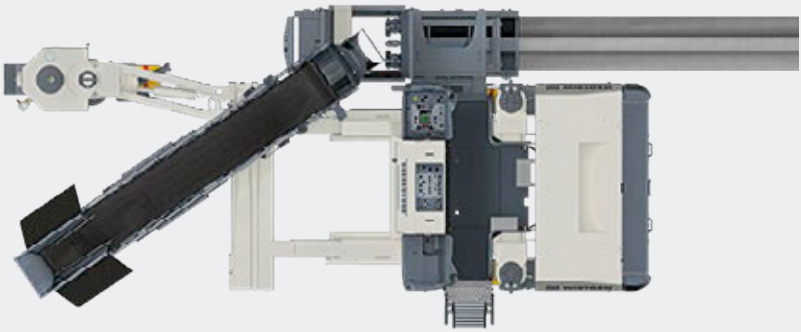

MAXIMUM FLEXIBILITY IN CONCRETE FEEDING

Perfect Choice

Various concrete feeding options

01



The Ideal Feeding System for Each Paving Situation

No two job sites are alike: special requirements such as narrow passages, bends, large offsets or high concrete volumes often call for special concrete feeding solutions. The SP 25 (i) has just the right answer to any of these situations: it can be fitted with an auger conveyor, belt conveyor or folding belt conveyor. The belt conveyor impresses with high conveying speed, ready access and ease of cleaning. The auger conveyor can be adjusted to an incline of up to 45° and is capable of holding extra

quantities to ensure continuous concrete supply during truck changes. And when equipped with the folding belt conveyor, the SP 25 (i) can be transported with ease even on small transport vehicles.

The different concrete feeding systems offer continuously adjustable conveying speeds. The hopper at the lower end of the feeding system is capable of holding large quantities of freshly delivered concrete.



01 The concrete feeding system - as shown here in belt conveyor design - can be slewed hydraulically to the left or right.

02 The SP 25(i) can optionally be fitted with an auger conveyor in lieu of the belt conveyor.

03 The concrete feeding system can be adjusted hydraulically from the operator's platform.

04 The hydraulically slewing cross-feeding auger is ideal for use as a buffer as it is capable of holding larger concrete volumes.



04

NUMEROUS OPTIONS FOR MOUNTING THE PAVING MOLD



01 - 02 Hydraulically telescoping offset paving mold.

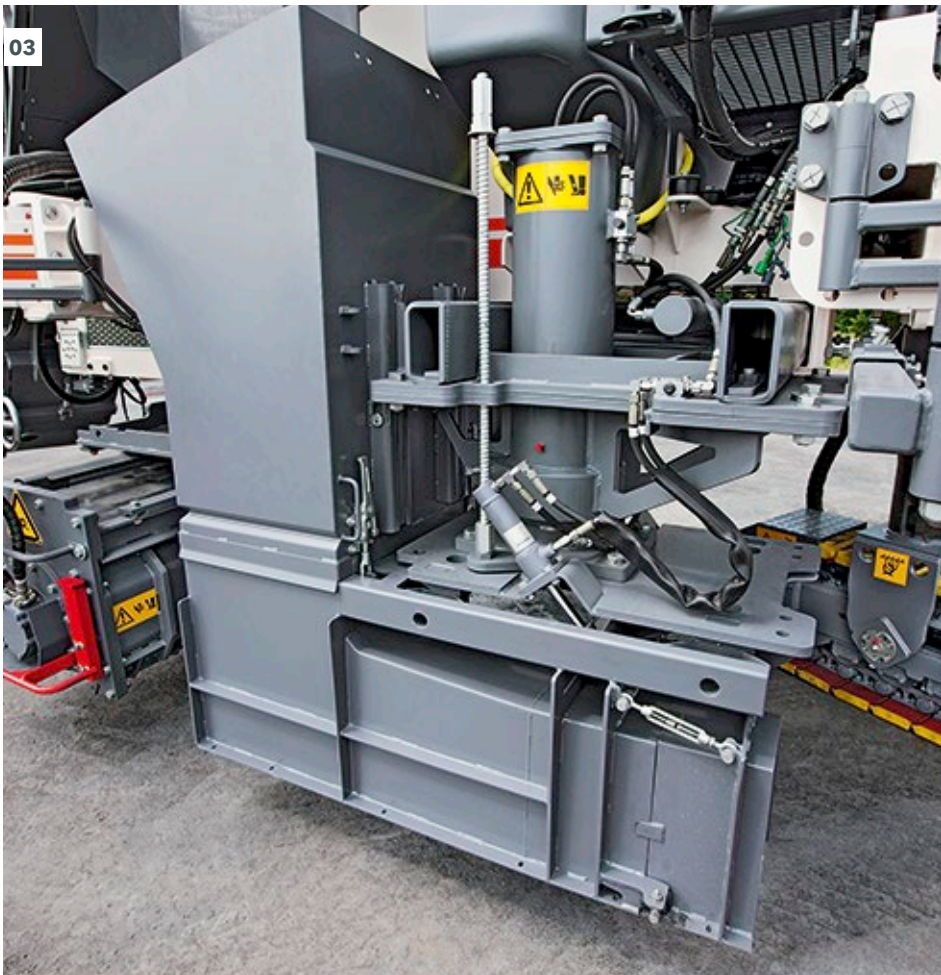

Mounting on Both Sides of the Paver

A big mark in favor of the SP 25(i): offset molds can be mounted on the left or right side of the machine. This feature enables both the paver and the mixer truck to move along with the flowing traffic while at the same time causing minimum disruptions.

In addition, the mold mount can be telescoped hydraulically by up to 1,100 mm to allow offset profiles to be paved far to one side of the machine frame. Height adjustment is effected via the track units.

03 The quick-change mold-mounting system allows kerb and gutter profiles to be exchanged quickly and easily.

Where complex paving situations require a specific connection of the mold to the machine frame, WIRTGEN offers solutions fully tailored to customer requirements.

Yet another highlight: the hydraulically operated quick-change mold-mounting system permits molds to be changed quickly and with only little effort. The operating principle is quite simple: lower machine, drive forward, secure – and here goes.



04 - 05 The mold can be mounted on the left or right – modification is completed within an extremely short time.



Maximum Versatility

Slipform paving mold at right or left

PERFECT PREPARATION OF THE BASE USING A TRIMMER

Level Base for a Perfect Paving Process

The design of the trimmer is based on our unmatched expertise gained in several decades of experience in cutting technology. The trimmer is fitted with picks arranged in a helical pattern, fine-grading an insufficiently level base to ensure uniform profile paving. The trimmer is arranged right in front of the paving mold and can be adjusted in height and cross

slope as well as telescoped to either side. The unit has a basic width of 600 mm and can be extended in increments to a maximum width of 1,600 mm.

Customized solutions – such as a trimmer conveying the material towards the periphery of the machine – can also be realized.

01 The trimmer offers numerous adjustment options via hydraulic cylinders.

02 The trimmer fine-grades the previously compacted base to a working depth of up to 150 mm.

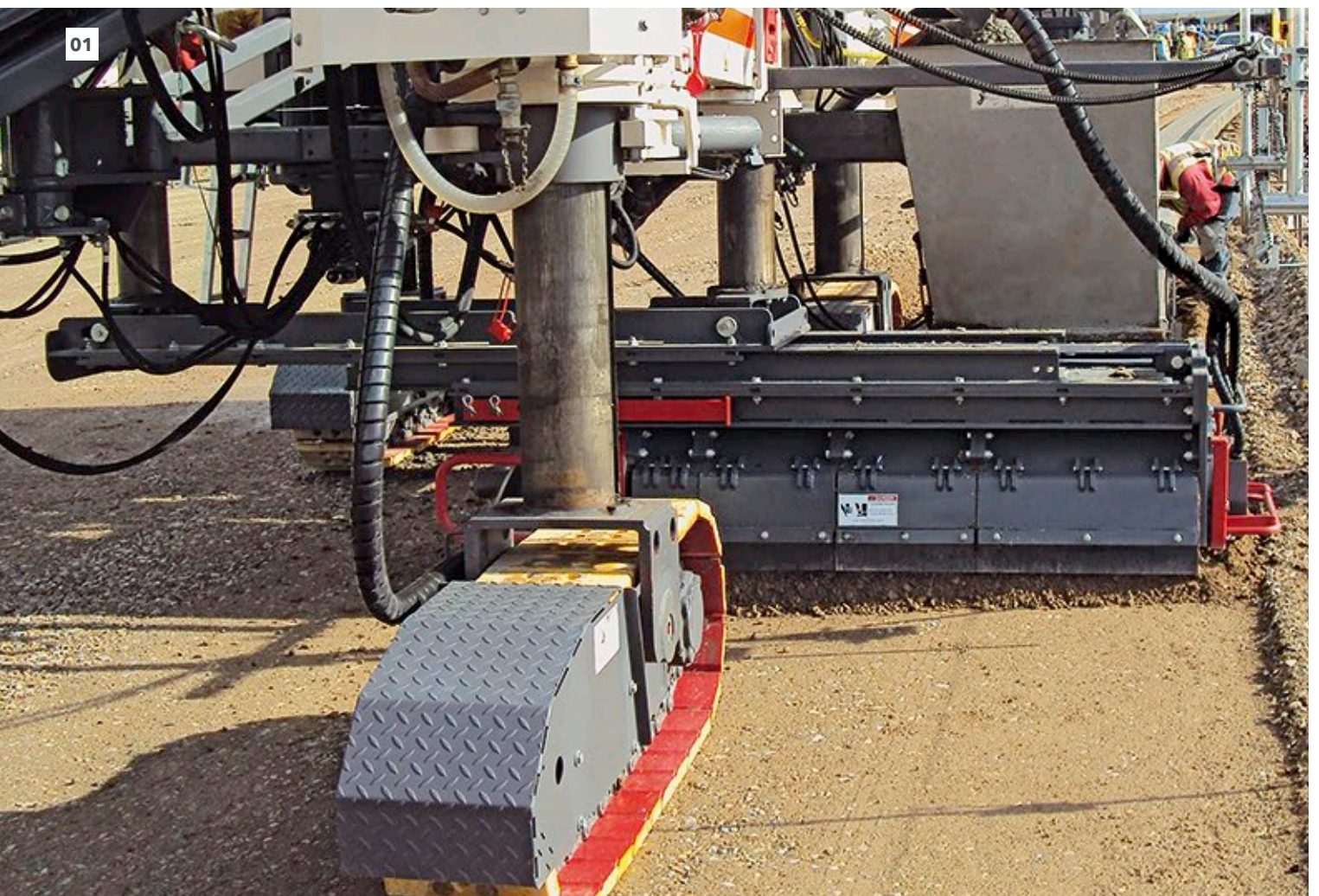

02

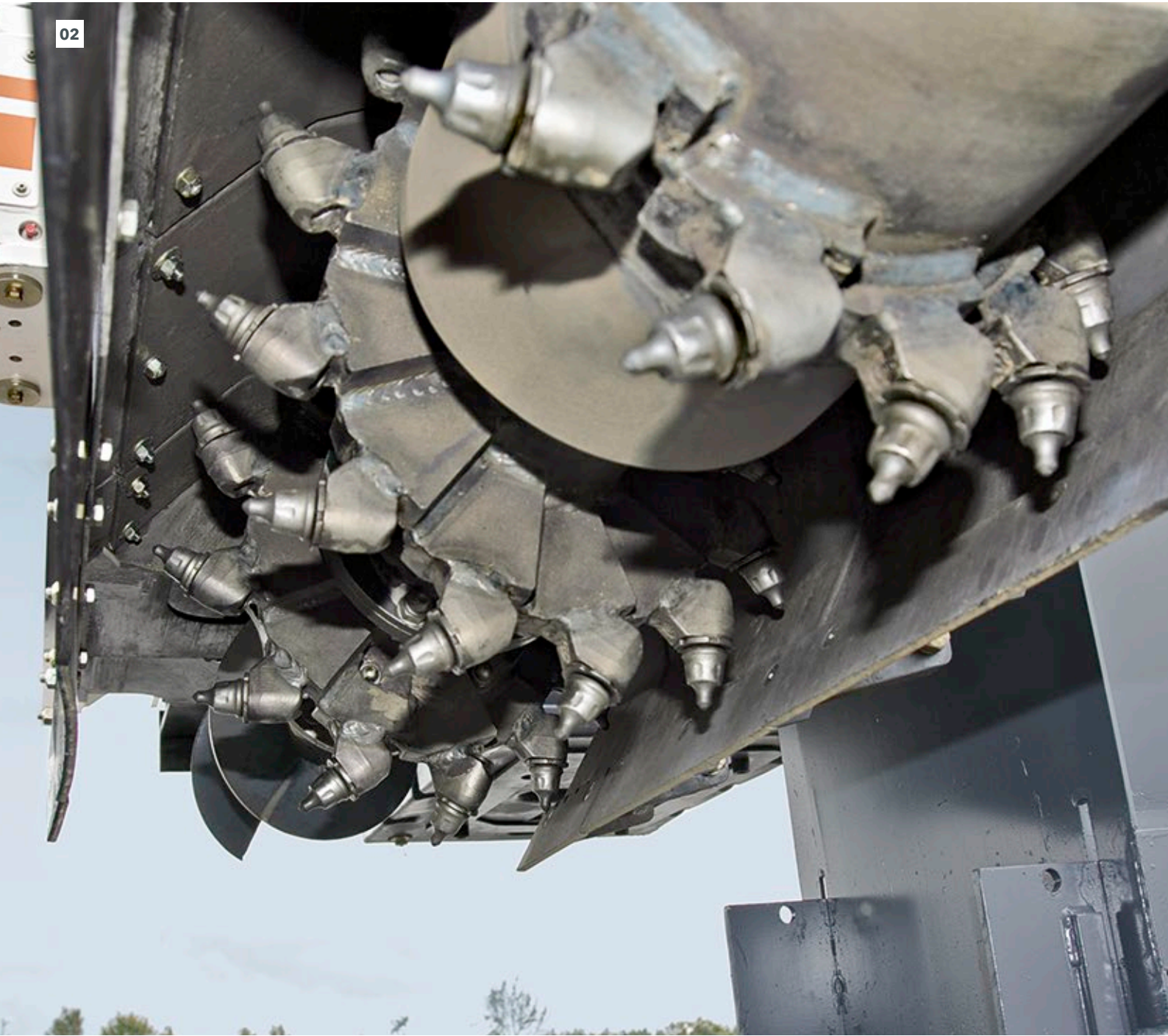

Automatically Levelled Sub-Base

Variably adjustable Trimmer

INTELLIGENT TRANSPORT CONCEPT

01



Fast Relocation without Special Permits
Compact transport dimensions

Suitable for Short Transport Vehicles or Trailers
Hydraulic folding conveyor



Optimized Machine Dimensions

Excellent manoeuvrability and an exceedingly compact design speed up loading and transport of the SP 25(i) slipform paver. Minimum effort is required to prepare the machine for transport.

The weather canopy can be lowered to transport height hydraulically, and the access ladder can be folded in for transport. And when equipped with the folding belt conveyor, the SP 25(i) can be transported with ease even on small transport vehicles.



01 Transport on a low-loader truck - a perfect match!

02 The weather canopy is lowered to transport height hydraulically.

03 In folding design, the belt conveyor can be folded hydraulically for transport.





The multifunctional slipform paver paves a wide range of monolithic profiles up to a height of 2.0 m. It can be used to pave concrete surfaces with widths of up to 3.5 m using both inset and offset methods (cannot be combined with all options). One or two hydraulic parallelogram swing legs at the front and two hydraulically telescoping track units at the rear enable extremely flexible concrete paving.



TECHNICAL SPECIFICATIONS	SP 25	SP 25 i
Range of applications	Offset paving / Inset paving	
Concrete Feeding System		
Belt conveyor	Length: 4,900 mm; belt width: 600 mm	
Belt conveyor, long (option)	Length: 5,900 mm; belt width: 600 mm	
Folding belt conveyor (option)	Length: 6,000 mm; belt width: 600 mm	
Auger conveyor (option)	Length: 4,600 mm; auger diameter: 400 mm	
Auger conveyor, long (option)	Length: 5,700 mm; auger diameter: 400 mm	
Concrete Equipment for Offset Paving		
Arrangement	Left / right	
Lateral adjustment of mold	1,100 mm	
Height adjustment of mold (option)	400 mm	
Max. mold height	2,000 mm ¹⁾	
Max. mold width	2,500 mm ¹⁾	
Cross-feeding auger	Length: 2,500 mm; auger diameter: 400 mm	
Concrete Equipment for Inset Paving (Option)		
Slab paving mold	1,000 mm to 3,500 mm	
Metering gate	1,000 mm to 3,500 mm	
Cross-spreading auger	2,000 mm to 3,500 mm	
Oscillating beam	2,000 mm to 3,500 mm	
Super smoother	2,000 mm to 3,500 mm	
Max. layer thickness	400 mm ¹⁾	
Vibration		
Connectors for hydraulic vibration	5 or 10 (option)	
Connectors for electric vibration (option)	5 or 10	
Trimmer (Option)		
Standard width	600 mm	
Max. width	1,600 mm ²⁾	
Working depth	0 to 150 mm	
Drum diameter with tools	500 mm	
Maximum lift	775 mm	
Hydraulic height adjustment	400 mm	
Mechanical height adjustment	375 mm	
Lateral adjustment of trimmer	1,900 mm	

TECHNICAL SPECIFICATIONS	SP 25	SP 25 i
Engine		
Engine manufacturer	Deutz	Deutz
Type	TCD 2012 L06 2V AG3	TCD 4.1 L4
Cooling	Water	Water
Number of cylinders	6	4
Rated power at 2,100 rpm	118 kW / 158 HP / 160 PS	115 kW / 154 HP / 156 PS
Displacement	6,057 cm ³	4,040 cm ³
Fuel consumption, full load field mix	32.0 l/h 14.3 l/h	30.2 l/h 13.5 l/h
Sound power level in accordance with EN 500-6 engine operator's platform	≤ 103 dB(A) ≥ 80 dB(A)	≤ 103 dB(A) ≥ 80 dB(A)
Exhaust emission standards	EU Stage 3a / US EPA Tier 3	EU Stage 5 / US EPA Tier 4f
Electrical System		
Voltage supply	24 V	
Filling Capacities		
Fuel	440 l	375 l
AdBlue® / DEF ³⁾	—	20 l
Hydraulic oil	135 l	
Water (option)	1,100 l (2 x 550 l)	
Driving Performance		
Operating speed	0 to 15 m/min	
Travel speed	0 to 35 m/min	
Track Units		
	Standard	Option
Number	3	4
Arrangement	2 x rear / 1 x front	1 x additional front
Dimensions (L x W x H)	1,580 x 300 x 540 mm	
Height Adjustment of Machine		
Hydraulic height adjustment	1,250 mm	
Mechanical height adjustment	560 mm	
Transport Dimensions (L x W x H)⁴⁾		
Basic machine without concrete feeding system	6,100 mm x 2,500 mm x 2,900 mm	
Basic machine with belt conveyor	8,300 mm x 2,500 mm x 2,950 mm	
Basic machine with folding belt conveyor	7,100 mm x 2,500 mm x 2,950 mm	
Basic machine with auger conveyor	7,900 mm x 2,500 mm x 2,950 mm	
Belt conveyor without chute	5,500 mm x 1,050 mm x 680 mm	
Folding belt conveyor without chute	6,600 mm x 1,050 mm x 930 mm	
Auger conveyor without chute	5,100 mm x 1,150 mm x 1,000 mm	
Trimmer	2,300 mm x 800 mm x 1,680 mm	
Machine Weights		
	Three-Track Design	Four-Track Design
Operating weight, CE ⁵⁾	11,500 to 22,500 kg	
Trimmer, working width 600 mm	1,300 kg	
Belt conveyor	850 kg	
Folding belt conveyor	920 kg	
Auger conveyor	1,300 kg	

¹⁾ Please consult factory for different special applications

²⁾ Please consult factory for special widths

³⁾ AdBlue® is a registered trademark of the Association of the Automotive Industry (Verband der Automobilindustrie e. V.; VDA)

⁴⁾ All specifications are minimum specifications without offset mold mounted on the paver

⁵⁾ Weight of machine, half weight of all consumables, machine operator (75 kg), on-board tool kit, no optional equipment; weights depend on the actual equipment installed and the working width

SIDE VIEW / TOP VIEW SP 25(i)

Offset machine: side view with belt conveyor

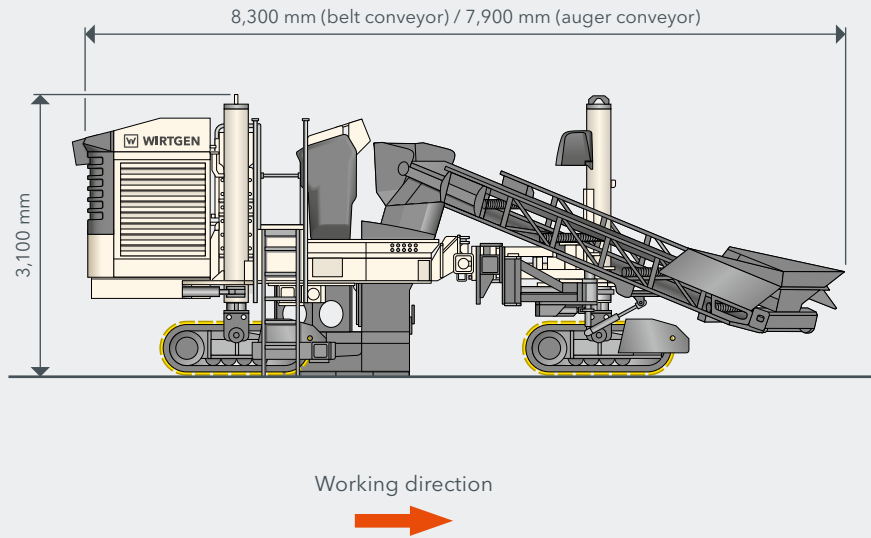

Offset machine: arrangement of track units

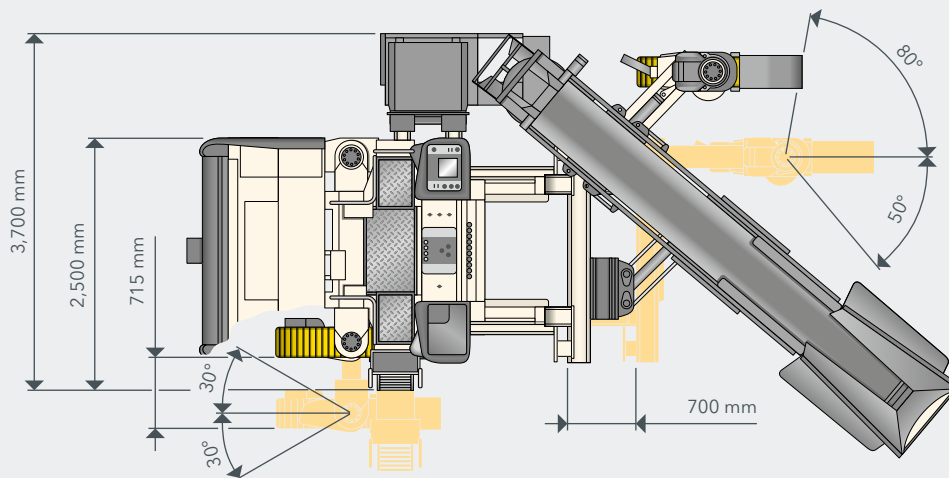

Telescoping feature for front section of machine frame

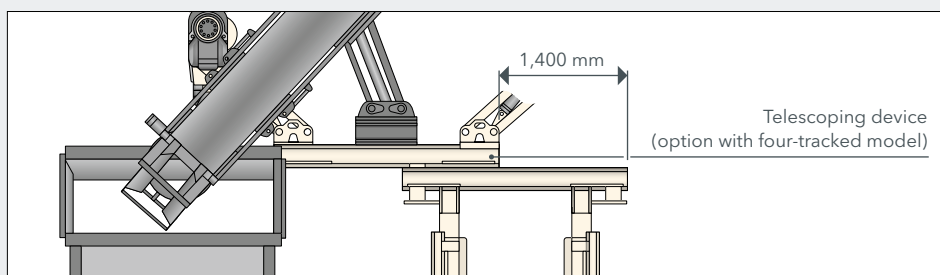

TOP VIEW SP 25(i)

Inset machine: top view with auger conveyor

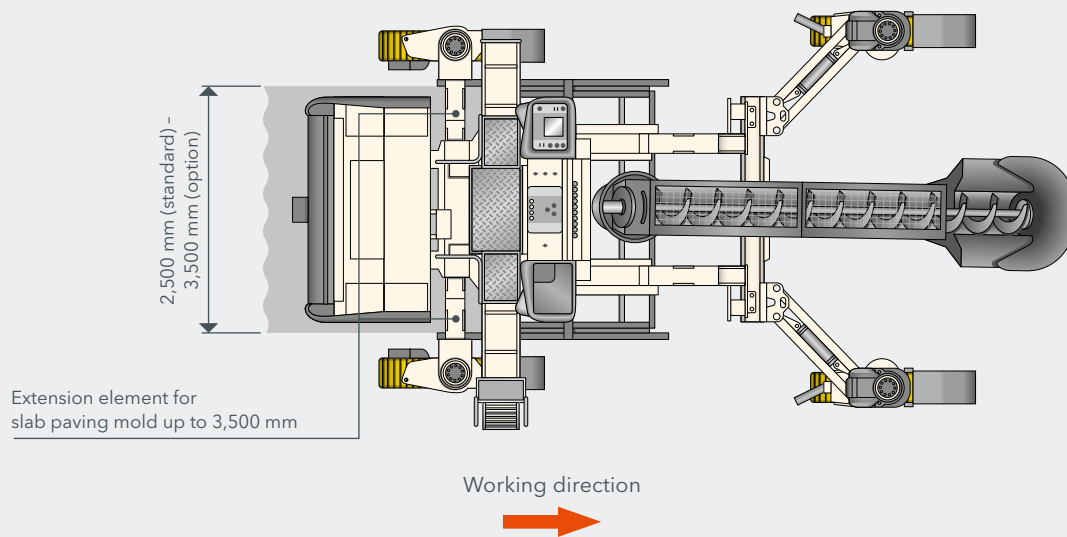

Offset machine: arrangement of track units and optional equipment features

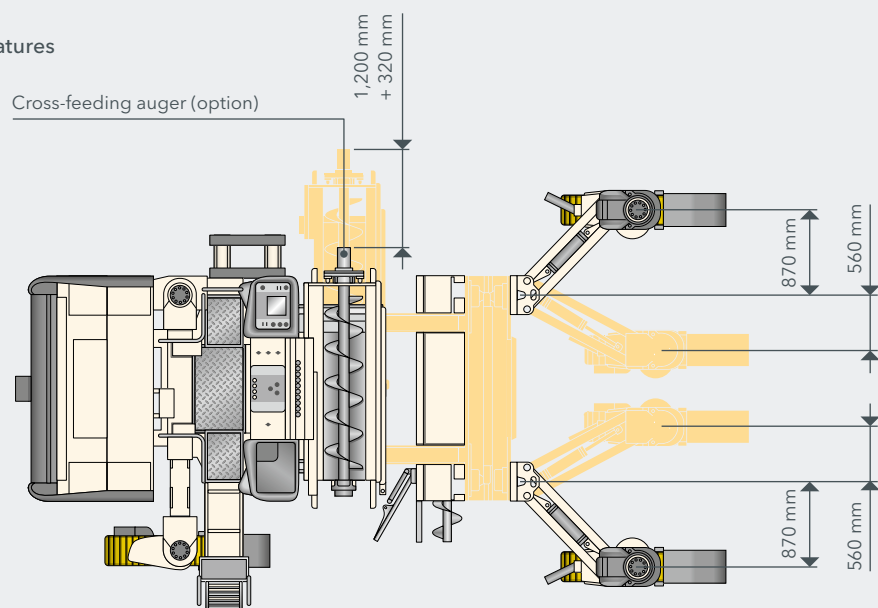

Incline of concrete feeding system

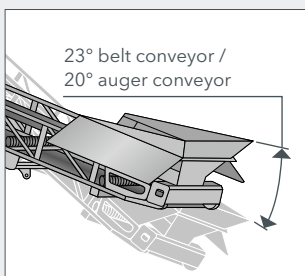

Longitudinal adjustment of belt conveyor

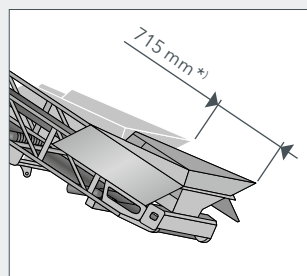

Mechanical height adjustment of belt conveyor

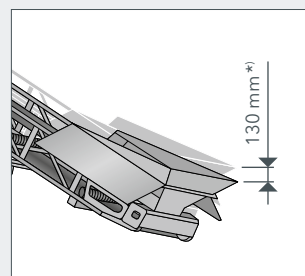

Slewing angle of belt conveyor

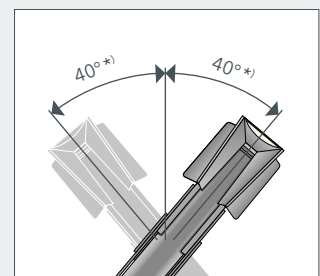

*) Details also applicable to auger conveyor

STANDARD EQUIPMENT	SP 25	SP 25 i
Basic Machine		
> 440 l fuel tank	■	—
> 375 l fuel tank	—	■
> 250 l hydraulic oil tank	■	■
> Electrical system (24 V)	■	■
> Hydraulic pump system	■	■
> Pressure-and-flow-controlled hydraulic pump, open circuit, for driving the track units	■	■
> Pressure-and-flow-controlled hydraulic pump, open circuit, for driving the hydraulic or electric vibrators or for driving the track units in second gear	■	■
> Pressure-controlled hydraulic pump, open circuit, for all cylinder functions	■	■
> A proportionally controlled hydraulic pump (closed circuit) for driving the auger conveyor or belt conveyor	■	■
Main Frame and Height Adjustment		
> Sturdy machine frame for accommodating two track units at the rear and one or two track units at the front	■	■
> Telescoping in length by 0.70 m to adjust the machine to site conditions or to allow mounting of a trimmer	■	■
> Telescoping in width by 0.715 m hydraulically at the rear by extending one or both rear track units to either improve machine stability in offset application when paving specific profiles, or to enable paving molds with a working width of up to 2.50 m to be mounted between the rear track units	■	■
Crawler Units and Chassis Linkage		
> Hydraulically driven track units, 1.56 m long, gear ratio 1:122, including towing device	■	■
> Continuously adjustable paving speed from 0 to 15 m/min	■	■
> Continuously adjustable transport speed from 0 to 35 m/min	■	■
> Hydraulic leveling cylinders with a stroke of 1.25 m	■	■
> Model with one pivoting front track unit connection (parallelogram arm)	□	□
> Three track units fitted with triple-grouser steel track pads	□	□

STANDARD EQUIPMENT	SP 25	SP 25 i
Machine Control, Leveling and Steering		
> Digital control system with LCD display that provides the operator with all of the relevant information and allows parameters such as the free choice of language (D / GB / F / E / NL) to be adjusted via a menu	■	■
> Proportional electrohydraulic leveling and steering by means of a PLC system including two leveling sensors, two steering sensors and one slope sensor	■	■
> Sensor mounting brackets, adjustable in height and range	■	■
Vibration		
> Hydraulic vibrator drive for up to 5 vibrators	□	□
> Two straight vibrators D66, hydraulically driven	□	□
Concrete Feeding System		
> Belt conveyor 4.90 m x 0.60 m with reversible hydraulic drive, hydraulically adjustable - without preliminary equipment	□	□
> Preliminary equipment for belt conveyor and charging auger with a length of 4,500 mm	□	□
> Steel chute	□	□
Concrete Equipment for Offset Paving		
> The offset paving molds can be mounted on the left or right side of the machine	■	■
> Offset mold mount telescoping hydraulically to one side; stroke: 1.10 m	□	□
> Offset paving mold up to 0.60 m wide, max. height of 0.40 m	□	□
Miscellaneous		
> Pre-fitting for installing the WITOS FleetView control unit	■	■
> European type certification, EuroTest mark and CE conformity	■	■
> Standard painting in RAL 9001 (cream)	□	□
> WITOS - professional telematics solution for machine operation and service optimization	□	□
> Lighting system including 3 halogen working lights, 24 V	□	□

■ = Standard equipment

□ = Standard equipment, can be replaced with optional equipment if desired

□ = Optional equipment

OPTIONAL EQUIPMENT	SP 25	SP 25 i
Main Frame and Height Adjustment		
> Extension element for telescoping device of machine frame, front	<input type="checkbox"/>	<input type="checkbox"/>
> Frame extension elements, rear, for 2.50 m to 3.50 m wide paving molds	<input type="checkbox"/>	<input type="checkbox"/>
> Frame extension elements at front, for paving mold from 2.50 m to 3.50 m width	<input type="checkbox"/>	<input type="checkbox"/>
Crawler Units and Chassis Linkage		
> Fourth track unit and two pivoting front track unit connections (parallelogram arms)	<input type="checkbox"/>	<input type="checkbox"/>
> Three track units fitted with polyurethane track pads	<input type="checkbox"/>	<input type="checkbox"/>
> Four track units fitted with triple-grouser steel track pads	<input type="checkbox"/>	<input type="checkbox"/>
> Four track units fitted with polyurethane track pads	<input type="checkbox"/>	<input type="checkbox"/>
Machine Control, Leveling and Steering		
> Two slab tracers	<input type="checkbox"/>	<input type="checkbox"/>
> Third height and steering sensor for paving in corners with tight radii	<input type="checkbox"/>	<input type="checkbox"/>
> Pre-fitting for 3D leveling	<input type="checkbox"/>	<input type="checkbox"/>
> Additional slope sensor for 3D leveling	<input type="checkbox"/>	<input type="checkbox"/>
> AutoPilot 2.0 (868 - 870 MHz) with Field Rover	<input type="checkbox"/>	<input type="checkbox"/>
> AutoPilot 2.0 (902 - 928 MHz) with Field Rover	<input type="checkbox"/>	—
> Training for AutoPilot 2.0	<input type="checkbox"/>	<input type="checkbox"/>
> Amplifier to extend the range of the AutoPilot signal. Radio frequency: 868 - 870 MHz	<input type="checkbox"/>	<input type="checkbox"/>
> Laser transmitter for AutoPilot 2.0 including stand	<input type="checkbox"/>	<input type="checkbox"/>
> Laser receiver for AutoPilot 2.0	<input type="checkbox"/>	<input type="checkbox"/>
> Ultrasonic sensor for AutoPilot 2.0	<input type="checkbox"/>	<input type="checkbox"/>
> Total station Leica iCON iCR80s for AutoPilot 2.0, 868 - 870 MHz	<input type="checkbox"/>	<input type="checkbox"/>
> Additional tablet computer with case for AutoPilot 2.0	<input type="checkbox"/>	<input type="checkbox"/>
Concrete Spreading Equipment for Slab Paving		
> Cross-spreading auger, 2.50 m long, suitable in particular for use with safety barrier molds and trimmer	<input type="checkbox"/>	<input type="checkbox"/>
> Spreading auger, 2.00 m, for paving mold	<input type="checkbox"/>	<input type="checkbox"/>
> Spreading auger - extension element 0.25 m, right-hand pitch	<input type="checkbox"/>	<input type="checkbox"/>
> Spreading auger - extension element 0.50 m, right-hand pitch	<input type="checkbox"/>	<input type="checkbox"/>
> Spreading auger - extension element 0.75 m, right-hand pitch	<input type="checkbox"/>	<input type="checkbox"/>
Vibration		
> Electric vibrator drive with 10-kVA generator for up to 5 vibrators	<input type="checkbox"/>	<input type="checkbox"/>
> Hydraulic and electric vibrator drive for up to 5 vibrators	<input type="checkbox"/>	<input type="checkbox"/>
> Two curved vibrators D66, hydraulically driven	<input type="checkbox"/>	<input type="checkbox"/>
> Two straight vibrators D66, electrically driven	<input type="checkbox"/>	<input type="checkbox"/>
> Two curved vibrators D66, electrically driven	<input type="checkbox"/>	<input type="checkbox"/>
> Hydraulic vibration, addition (5x)	<input type="checkbox"/>	<input type="checkbox"/>
> Electric vibration, addition (5x)	<input type="checkbox"/>	<input type="checkbox"/>
> Straight vibrator D66, hydraulically driven	<input type="checkbox"/>	<input type="checkbox"/>
> Curved vibrator D66, hydraulically driven	<input type="checkbox"/>	<input type="checkbox"/>
> Straight vibrator D66, electrically driven	<input type="checkbox"/>	<input type="checkbox"/>
> Curved vibrator D66, electrically driven	<input type="checkbox"/>	<input type="checkbox"/>

OPTIONAL EQUIPMENT	SP 25	SP 25 i
Concrete Equipment for Slab Paving		
> Paving mold series 900m, basic width 1.00 m	<input type="checkbox"/>	<input type="checkbox"/>
> Paving mold series 900m / 910m - extension element 0.25 m	<input type="checkbox"/>	<input type="checkbox"/>
> Paving mold series 900m - extension element 0.50 m	<input type="checkbox"/>	<input type="checkbox"/>
> Paving mold series 900m - extension element 0.75 m	<input type="checkbox"/>	<input type="checkbox"/>
> Paving mold series 900m - extension element 1.00 m	<input type="checkbox"/>	<input type="checkbox"/>
> Ancillary parts for mounting paving molds (2.50 m to 3.50 m)	<input type="checkbox"/>	<input type="checkbox"/>
> Trailing side plate, 2.80 m long, with trailing side header extension	<input type="checkbox"/>	<input type="checkbox"/>
> Metering gate for paving mold - basic width 1.00 m	<input type="checkbox"/>	<input type="checkbox"/>
> Hydraulic height adjustment for metering gate	<input type="checkbox"/>	<input type="checkbox"/>
> Metering gate - extension element 0.25 m	<input type="checkbox"/>	<input type="checkbox"/>
> Metering gate - extension element 0.50 m	<input type="checkbox"/>	<input type="checkbox"/>
> Metering gate - extension element 0.75 m	<input type="checkbox"/>	<input type="checkbox"/>
> Metering gate - extension element 1.00 m	<input type="checkbox"/>	<input type="checkbox"/>
> Oscillating beam - basic width 2.00 m	<input type="checkbox"/>	<input type="checkbox"/>
> Oscillating beam - extension element 0.25 m	<input type="checkbox"/>	<input type="checkbox"/>
> Oscillating beam - extension element 0.50 m	<input type="checkbox"/>	<input type="checkbox"/>
> Oscillating beam - extension element 0.75 m	<input type="checkbox"/>	<input type="checkbox"/>
> Super smoother - basic width 2.00 m	<input type="checkbox"/>	<input type="checkbox"/>
> Super smoother - extension element 0.25 m	<input type="checkbox"/>	<input type="checkbox"/>
> Super smoother - extension element 0.50 m	<input type="checkbox"/>	<input type="checkbox"/>
Concrete Feeding System		
> Belt conveyor 5.90 m x 0.60 m with reversible hydraulic drive, hydraulically adjustable - without preliminary equipment	<input type="checkbox"/>	<input type="checkbox"/>
> Belt conveyor 6.00 m x 0.60 m, folding, with reversible hydraulic drive, hydraulically adjustable - without preliminary equipment	<input type="checkbox"/>	<input type="checkbox"/>
> Charging auger 4.60 m x 0.40 m with reversible hydraulic drive, hydraulically adjustable - without preliminary equipment	<input type="checkbox"/>	<input type="checkbox"/>
> Charging auger 5.70 m x 0.40 m with reversible hydraulic drive, hydraulically adjustable - without preliminary equipment	<input type="checkbox"/>	<input type="checkbox"/>
> Preliminary equipment for charging auger with a length of 5,700 mm	<input type="checkbox"/>	<input type="checkbox"/>
> Steel-rubber chute is used to guide the concrete to the offset mold	<input type="checkbox"/>	<input type="checkbox"/>

■ = Standard equipment

■ = Standard equipment, can be replaced with optional equipment if desired

□ = Optional equipment

OPTIONAL EQUIPMENT	SP 25	SP 25 i
Concrete Equipment for Offset Paving		
> Offset mold mount telescoping hydraulically to both sides; stroke: 1.10 m	<input type="checkbox"/>	<input type="checkbox"/>
> Offset paving mold from 0.60 m to 1.20 m wide, max. height of 0.40 m	<input type="checkbox"/>	<input type="checkbox"/>
> Offset paving mold from 1.20 m to 1.80 m wide, max. height of 0.40 m	<input type="checkbox"/>	<input type="checkbox"/>
> Offset paving mold up to 0.90 m high, max. base width of 0.60 m, including hopper	<input type="checkbox"/>	<input type="checkbox"/>
> Offset paving mold up to 1.30 m high, max. base width of 0.60 m, including hoppe	<input type="checkbox"/>	<input type="checkbox"/>
> Split offset paving mold up to 0.60 m wide, max. height of 0.40 m	<input type="checkbox"/>	<input type="checkbox"/>
> Split offset paving mold from 0.60 m to 1.20 m wide, max. height of 0.40 m	<input type="checkbox"/>	<input type="checkbox"/>
> Split combined offset mold up to 0.75 m in width and a maximum of 0.40 m in height	<input type="checkbox"/>	<input type="checkbox"/>
> Split combined offset mold up to 1.10 m in width and a maximum of 0.40 m in height	<input type="checkbox"/>	<input type="checkbox"/>
> Offset paving mold up to 0.60 m wide, max. height of 0.40 m	<input type="checkbox"/>	<input type="checkbox"/>
> Offset paving mold from 0.60 m to 1.20 m wide, max. height of 0.40 m	<input type="checkbox"/>	<input type="checkbox"/>
> Offset paving mold from 1.20 m to 1.80 m wide, max. height of 0.40 m	<input type="checkbox"/>	<input type="checkbox"/>
> Offset paving mold up to 0.90 m high, max. base width of 0.60 m, including hopper	<input type="checkbox"/>	<input type="checkbox"/>
> Offset paving mold up to 1.30 m high, max. base width of 0.60 m, including hopper	<input type="checkbox"/>	<input type="checkbox"/>
> Split offset paving mold up to 0.60 m wide, max. height of 0.40 m	<input type="checkbox"/>	<input type="checkbox"/>
> Split offset paving mold from 0.60 m to 1.20 m wide, max. height of 0.40 m	<input type="checkbox"/>	<input type="checkbox"/>
> Bottom part for split offset paving mold (AV) up to 0.60 m wide (max. height of 0.40 m)	<input type="checkbox"/>	<input type="checkbox"/>
> Bottom part for split offset paving mold (AV) from 0.60 m to 1.20 m wide (max. height of 0.40 m)	<input type="checkbox"/>	<input type="checkbox"/>
> Split combined offset mold up to 0.75 m in width and a maximum of 0.40 m in height	<input type="checkbox"/>	<input type="checkbox"/>
> Split combined offset mold up to 1.10 m in width and a maximum of 0.40 m in height	<input type="checkbox"/>	<input type="checkbox"/>
> Profile insert for split combined offset mold up to 0.75 m in width	<input type="checkbox"/>	<input type="checkbox"/>
> Profile insert for split combined offset mold up to 1.10 m in width	<input type="checkbox"/>	<input type="checkbox"/>
> Height adapter for split offset paving molds	<input type="checkbox"/>	<input type="checkbox"/>
> Height-adjustable mold mount with 0.40 m lift for split offset mold	<input type="checkbox"/>	<input type="checkbox"/>
> Hydraulic quick-change system for offset paving mold (one-piece mold)	<input type="checkbox"/>	<input type="checkbox"/>
> Additional adapter plate for quick-change system	<input type="checkbox"/>	<input type="checkbox"/>
> Hydraulic quick-change system for offset paving mold (two-piece mold)	<input type="checkbox"/>	<input type="checkbox"/>
> Set of hydraulic components for adjusting the sideplate of an EV offset paving mold	<input type="checkbox"/>	<input type="checkbox"/>
> Set of hydraulic components for adjusting the sideplate of an AV offset mold	<input type="checkbox"/>	<input type="checkbox"/>
Offset Trimmer		
> Preliminary equipment for installing a trimmer	<input type="checkbox"/>	<input type="checkbox"/>
> Trimmer, basic width, 0.60 m, for mounting on the left side	<input type="checkbox"/>	<input type="checkbox"/>
> Trimmer - extension 0.20 m wide, for mounting on the left side	<input type="checkbox"/>	<input type="checkbox"/>
> Trimmer - extension 0.40 m wide, for mounting on the left side	<input type="checkbox"/>	<input type="checkbox"/>
> Trimmer, basic width, 0.60 m, for mounting on the right side	<input type="checkbox"/>	<input type="checkbox"/>
> Trimmer - extension 0.20 m wide, for mounting on the right side	<input type="checkbox"/>	<input type="checkbox"/>
> Trimmer - extension 0.40 m wide, for mounting on the right side	<input type="checkbox"/>	<input type="checkbox"/>

OPTIONAL EQUIPMENT	SP 25	SP 25 i
Operator's Platform		
> Weather umbrella for operator's platform	<input type="checkbox"/>	<input type="checkbox"/>
> Weather canopy for operator's platform, hydraulically telescoping in height	<input type="checkbox"/>	<input type="checkbox"/>
Miscellaneous		
> Painting in one special color (RAL)	<input type="checkbox"/>	<input type="checkbox"/>
> Painting in two special colors (RAL)	<input type="checkbox"/>	<input type="checkbox"/>
> Model without WITOS	<input type="checkbox"/>	<input type="checkbox"/>
> High-performance lighting system including 3 LED working lights, 24 V	<input type="checkbox"/>	<input type="checkbox"/>
> Lighting system including 4 halogen working lights, 24 V	<input type="checkbox"/>	<input type="checkbox"/>
> High-performance lighting system including 4 LED working lights, 24 V	<input type="checkbox"/>	<input type="checkbox"/>
> High-performance lighting package with 6 LED working lights, 24 V	<input type="checkbox"/>	<input type="checkbox"/>
> High-performance lighting system including 8 LED working lights, 24 V	<input type="checkbox"/>	<input type="checkbox"/>
> Hydraulic high-pressure water cleaning system with 550 l plastic tank	<input type="checkbox"/>	<input type="checkbox"/>
> Additional water pump, 24 V	<input type="checkbox"/>	<input type="checkbox"/>
> Additional plastic water tank, 550 l	<input type="checkbox"/>	<input type="checkbox"/>
> Camera system consisting of 1 camera and 1 screen, expandable to up to 6 cameras	<input type="checkbox"/>	<input type="checkbox"/>
> Additional camera as an extension to an existing camera system	<input type="checkbox"/>	<input type="checkbox"/>
> Two LED floodlights 24 V	<input type="checkbox"/>	<input type="checkbox"/>
> Two LED floodlights including power generator (110 V)	<input type="checkbox"/>	<input type="checkbox"/>
> Two LED floodlights including power generator (230 V)	<input type="checkbox"/>	<input type="checkbox"/>
> 110 volt power generator, hydraulically driven, rated power of 4 kW	<input type="checkbox"/>	<input type="checkbox"/>
> 230 volt power generator, hydraulically driven, rated power of 4 kW	<input type="checkbox"/>	<input type="checkbox"/>
> Truck pushing device	<input type="checkbox"/>	<input type="checkbox"/>
> Additional storage compartment at machine rear	<input type="checkbox"/>	<input type="checkbox"/>
> Stringline tensioning system, complete with 1,000 m steel wire rope	<input type="checkbox"/>	<input type="checkbox"/>
> Additional tensioning winch for stringline tensioning system	<input type="checkbox"/>	<input type="checkbox"/>
> Stringline tensioning system, complete with 4 x 300 m nylon rope	<input type="checkbox"/>	<input type="checkbox"/>
> Radius kit, fibreglass rod as stringline replacement for paving in corners with different radii	<input type="checkbox"/>	<input type="checkbox"/>
> Machine commissioning (day rate)	<input type="checkbox"/>	<input type="checkbox"/>
> Export packaging	<input type="checkbox"/>	<input type="checkbox"/>

■ = Standard equipment

■ = Standard equipment, can be replaced with optional equipment if desired

□ = Optional equipment

**WIRTGEN GmbH**

Reinhard-Wirtgen-Str. 2
53578 Windhagen
Germany

T: +49 2645 131-0
F: +49 2645 131-392
M: info@wirtgen.com

 www.wirtgen.de



For further information, please scan the code.