

A WIRTGEN GROUP COMPANY



KLEEMANN



MOBIREX EVO2

MOBILE IMPACT CRUSHER MR 110(i) EVO2 | MR 130(i) EVO2



> THE POWERFUL ALL-ROUNDER



MOBIREX MR 110(i) | 130(i) EVO2

Whether in the quarry or for recycling - the MOBIREX MR 110(i)/130(i) EVO2 impact crushers crush feed material efficiently and produce top product quality. Simple transport, short set-up times and high machine availability make them the ideal all-rounders - even with work sites that change at short notice.



Focus on flexibility



Efficiency in the foreground



Operability at a glance



MOBIREX MR 110(i) | 130(i) EVO2

MR 110(i) EVO2 hopper volume:
4.4 m³, 8 m³ with extension

MR 130(i) EVO2 hopper volume:
5 m³, 9 m³ with extension

Single-deck vibrating screen and double-deck vibrating screen

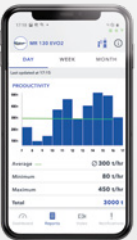

SPECTIVE
CONNECT

+ Option

<p>1 Feeding unit</p>	<p>4 Crusher unit</p>	<p>7 Post screening unit and magnetic separator</p>
<p>2 Prescreening</p>	<p>5 Drive</p>	<p>> Material flow</p>
<p>3 Continuous Feed System CFS</p>	<p>6 SPECTIVE control system</p>	<p>> Handling and sustainability</p>



1 Feeding unit

- > Generously dimensioned basic hopper for simple and fast loading
- > Can be folded and locked hydraulically - for faster set-up from the ground via radio remote control

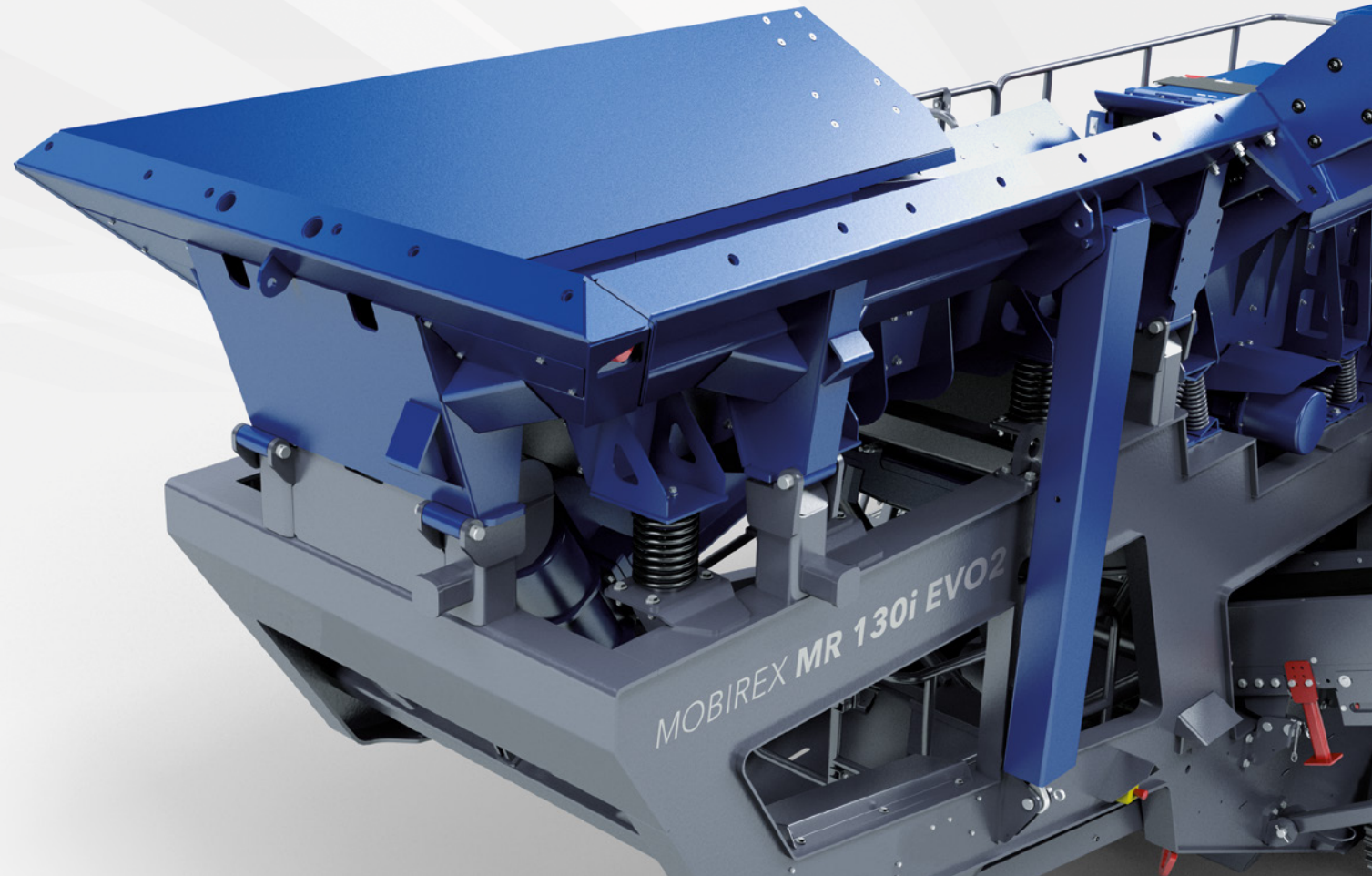

1 Feeding unit

2 Prescreening

3 Continuous Feed System CFS

4 Crusher unit

5 Drive

6 SPECTIVE control system

7 Post screening unit and magnetic separator

> Material flow

> Handling and sustainability



2 Prescreening

- > Independently vibrating double-deck prescreening guarantees effective screening of fine material for optimal final product quality
- > Reduction in wear is achieved by redirecting medium-sized grain through the large crusher bypass
- > Discharge of fines via the side discharge conveyor⁺; conveyor can be installed flexibly on the right or left, rigid or hydraulically foldable



⁺ Option

1 Feeding unit

2 Prescreening

3 Continuous Feed System CFS

4 Crusher unit

5 Drive

6 SPECTIVE control system

7 Post screening unit and magnetic separator

> Material flow

> Handling and sustainability

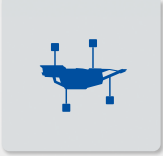

3 Continuous Feed System CFS

- > Continuous crusher load through the intelligent CFS feed control:
 - > Based on crusher and engine utilisation, the material feed is adjusted continuously and without a delay by the vibrating feeder and prescreen
- > Less burden is placed on the downstream components, wear is also reduced and the share of oversize grain is minimised

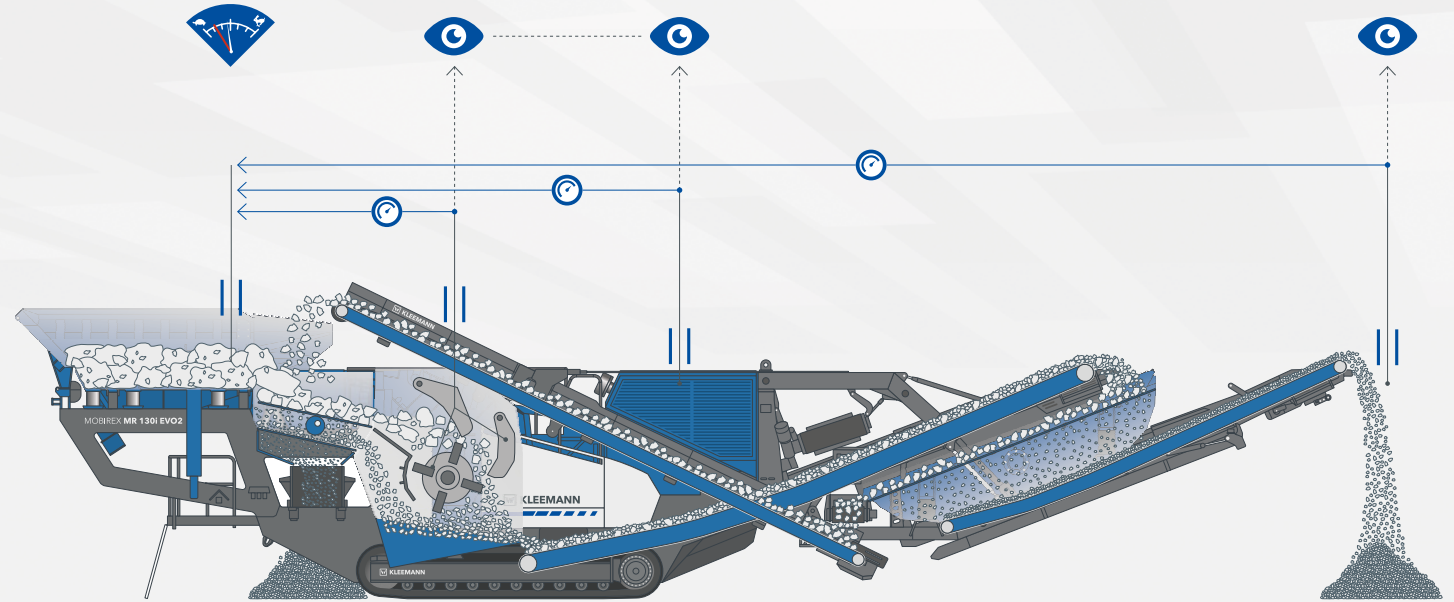

<p>1 Feeding unit</p>	<p>4 Crusher unit</p>	<p>7 Post screening unit and magnetic separator</p>
<p>2 Prescreening</p>	<p>5 Drive</p>	<p>> Material flow</p>
<p>3 Continuous Feed System CFS</p>	<p>6 SPECTIVE control system</p>	<p>> Handling and sustainability</p>



4 Crusher unit

- > Optimal inlet geometry for improved material feed behaviour and therefore increased throughput
- > Fewer blockages in the crusher inlet area thanks to the crusher inlet cover which can be raised hydraulically and the upper impact toggle (radio-controlled)
- > Increased product quality thanks to C-shape rotor ledges for better impact over long periods

Fully hydraulic gap adjustment and overload system

- > Automatic zero-point determination for precise gap setting via touch panel
- > The effective overload system opens the lower impact toggle in the event of uncrushable elements and then moves back automatically to the preset value
- > As a final safety feature, a bursting disc protects the crusher against excessively large uncrushable elements

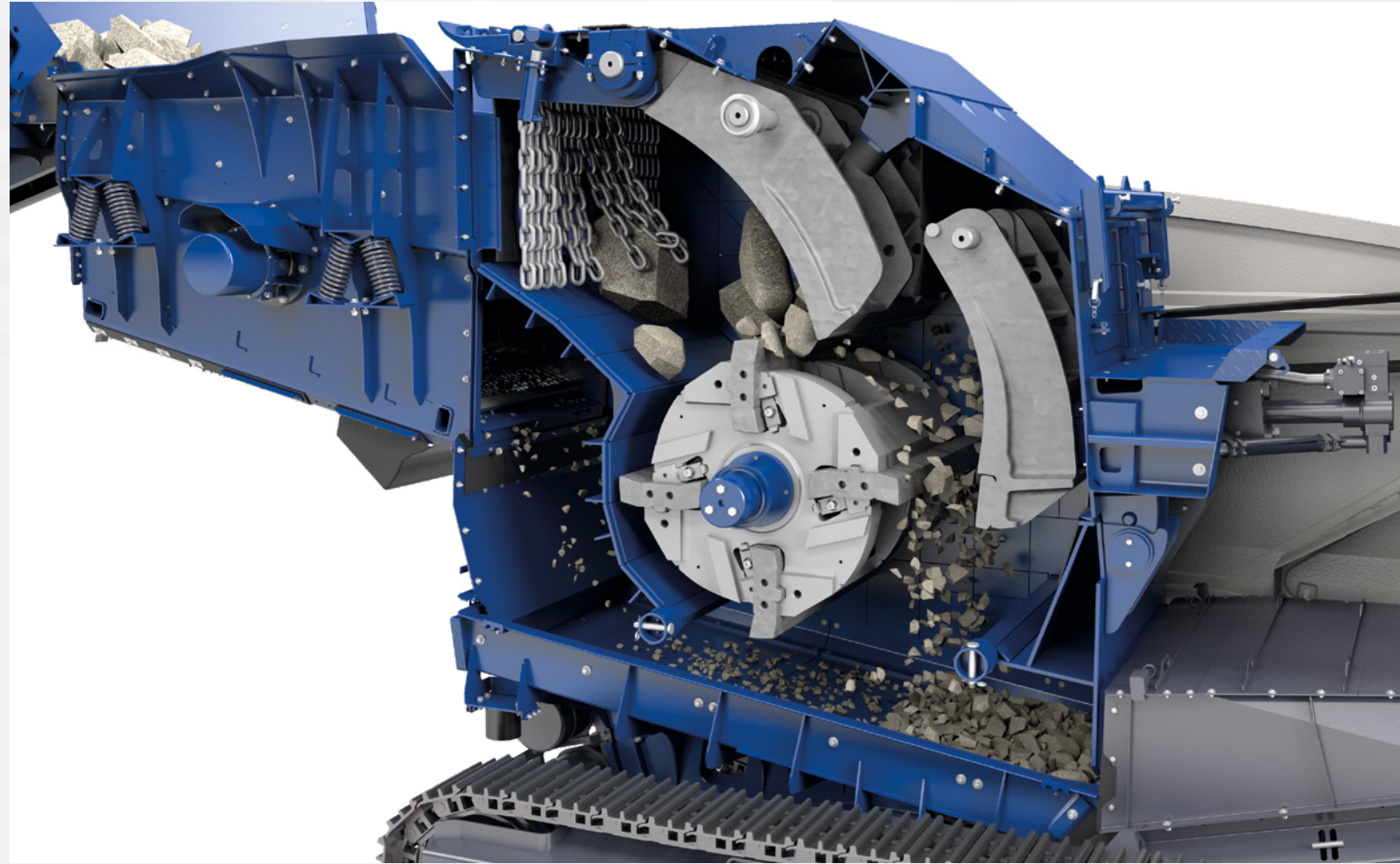

1 Feeding unit

2 Prescreening

3 Continuous Feed System CFS

4 Crusher unit

5 Drive

6 SPECTIVE control system

7 Post screening unit and magnetic separator

> Material flow

> Handling and sustainability



5 Drive

 Efficient and powerful crusher D-DRIVE direct drive with low fuel consumption, conveyors are driven electrically

> Heat package⁺ (-15 to +50 °C) or cold package⁺ (-25 to +40 °C)



KLEEMANN SUSTAINABILITY describes innovative technologies and solutions which are consistent with the sustainability objectives of the WIRTGEN GROUP.

⁺ Option

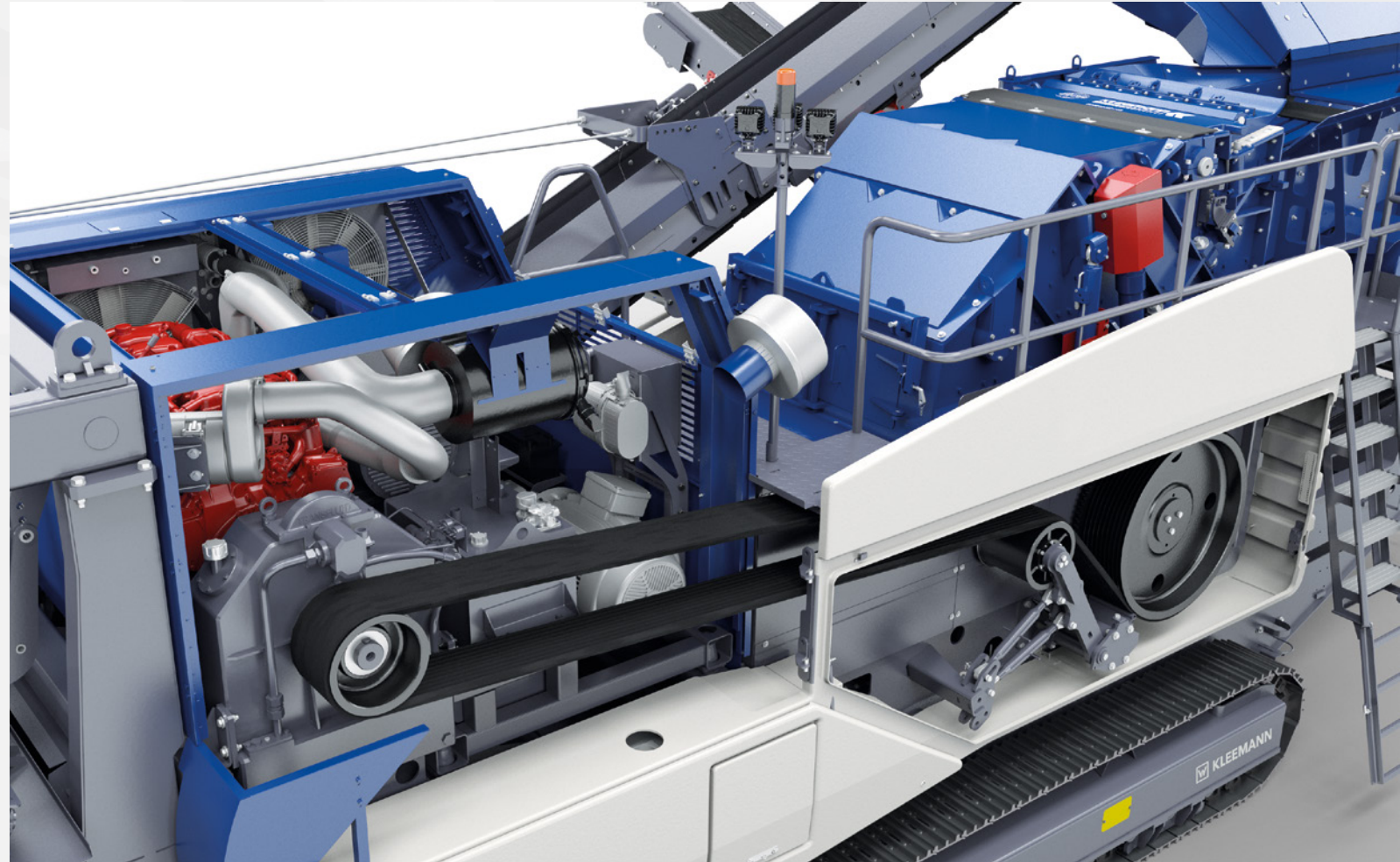

1 Feeding unit

2 Prescreening

3 Continuous Feed System CFS

4 Crusher unit

5 Drive

6 SPECTIVE control system

7 Post screening unit and magnetic separator

> Material flow

> Handling and sustainability

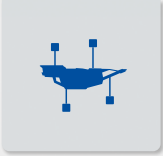

6 SPECTIVE control system

- > **SPECTIVE touch panel:** with menu-guided operation, visualisation and support; status display of all components such as speed, temperature, etc., rapid fault localisation and diagnostics
- > **SPECTIVE CONNECT⁺:** all important information is displayed directly on the smartphone
- > **WITOS FleetView telematics system:** efficient fleet and service management with information on the plant's operating status regardless of location and time
- > **Quick Track⁺:** fast and simple shifting of the machine to operating mode; operation takes place conveniently via the remote control

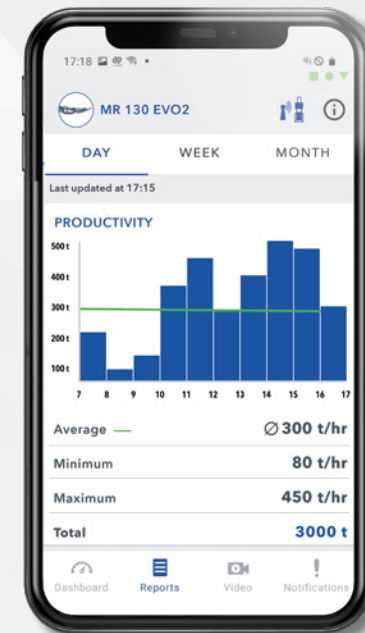

SPECTIVE

SPECTIVE
CONNECT

+ Option

1 Feeding unit	4 Crusher unit	7 Post screening unit and magnetic separator
2 Prescreening	5 Drive	> Material flow
3 Continuous Feed System CFS	6 SPECTIVE control system	> Handling and sustainability

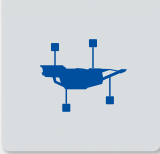

7 Post screening unit and magnetic separator

> **Post screening unit⁺** available in two versions:

- > Single-deck vibrating screen for the production of a classified final grain size
- > Double-deck vibrating screen for the production of two classified final grain sizes (only for the MR 110(i) EVO2, for MR 130(i) EVO2 upon request)

> Return conveyor for closed material loop; 100° swivel-mounted for side discharge

> The wind sifter⁺ guarantees increased material quality, removal of contamination (e.g. wood and plastic), air flow setting according to the material, 2nd wind sifter⁺ available with the optional double-deck post screening unit

Magnetic separator

- > High-performance electric or permanent magnet⁺ for maximum output
- > Stepless raising and lowering parallel to crusher discharge conveyor; radio control is also possible



⁺ Option

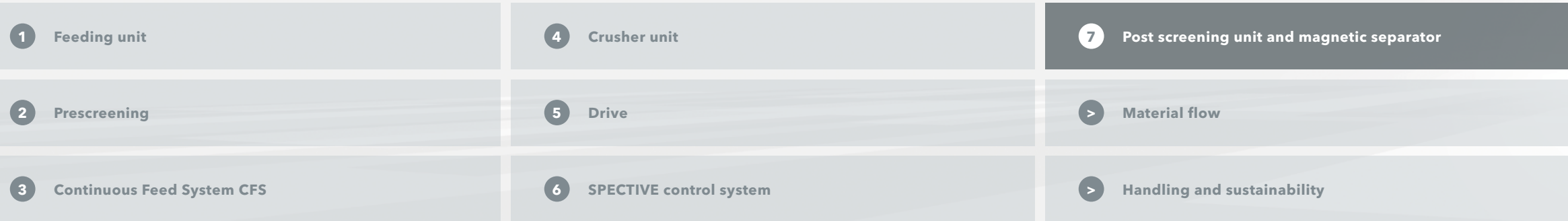

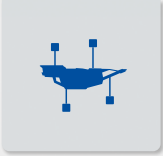

> Optimised material flow

- > Tried-and-tested material flow concept: extension of system widths across all components in the direction of material flow; the material flow is not narrowed
- > Prevention of material congestion

- > Higher total throughput with lower fuel consumption
- > Longer service life thanks to reduced wear

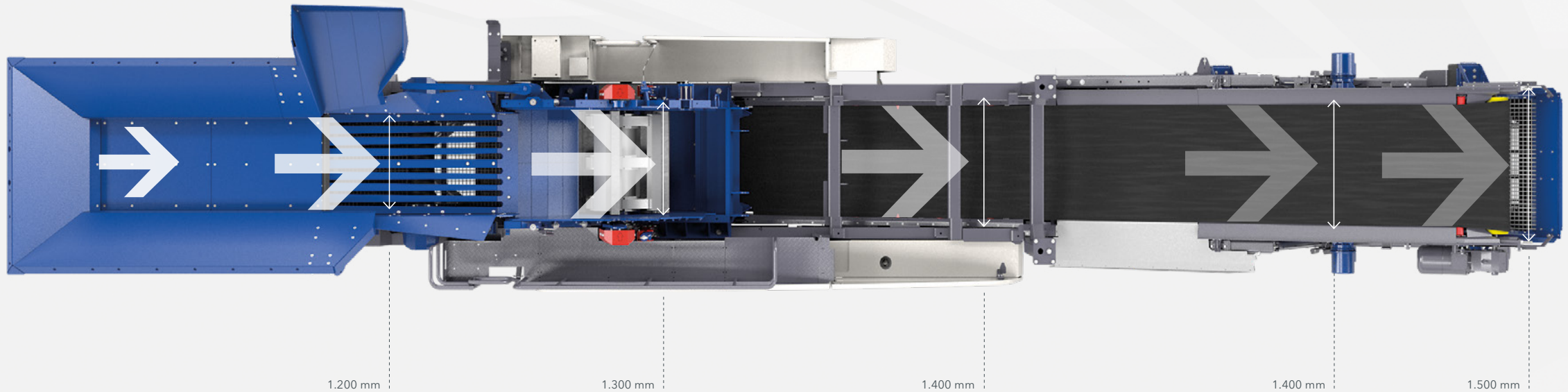

1 Feeding unit

2 Prescreening

3 Continuous Feed System CFS

4 Crusher unit

5 Drive

6 SPECTIVE control system

7 Post screening unit and magnetic separator

> Material flow

> Handling and sustainability

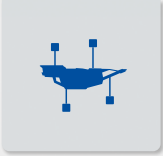

> Transport

- > Increased ground clearance in the area of the post screening unit for better transportability
- > Simple disassembly of the post screening unit for individual transport

> Safety and ergonomics

- > Quick and convenient servicing thanks to easy physical and visual access to all components
- > Spray system and LED lighting for extended illumination of work areas included in basic plant; premium lighting⁺

Lock & Turn safety system

- > The key transfer safety permits work in certain areas of the crusher only if they are mechanically secured
- > Lock: the rotor Lock & Turn safety system secures the rotor and guarantees safe maintenance
- > Turn: simple positioning of the rotor by the turning device

> Environment

- > Environmentally-compatible solutions for reducing noise and dust
- > Solutions for noise reduction⁺: insulation of the noise sources via an ergonomic power pack housing, reduction of noise by 6 decibels (3 decibels are the equivalent of a reduction of 50 % for the human ear)
- > Solutions for dust containment: an effective spray system at different material transfer points of the plant, e.g. crusher inlet, crusher discharge conveyor, side discharge conveyor, post screening unit



⁺ Option

1 Feeding unit

2 Prescreening

3 Continuous Feed System CFS

4 Crusher unit

5 Drive

6 SPECTIVE control system

7 Post screening unit and magnetic separator

> Material flow

> Handling and sustainability

TECHNICAL INFORMATION	MR 110(i) EVO2	MR 130(i) EVO2
Feed capacity up to approx. (t/h)	350	450
Crusher inlet (W x H) (mm)	1,100 x 800	1,300 x 900
Max. feed size (mm)	880 x 550	1,040 x 650
Transport height without options (mm)	3,600	3,750
Transport length without options (mm)	17,340	18,385
Transport width without options (mm)	3,000	3,000
Transport length with single-deck screening unit (mm)	21,110	21,620
Transport width with single-deck screening unit (mm)	3,050	3,150 - 3,400
Transport weight of single-deck screening unit (kg)	6,100	6,500
Transport weight of basic plant - max. configuration (kg)	44,500 - 60,500	49,500 - 64,500



KLEEMANN GmbH

Manfred-Wörner-Str. 160
73037 Göppingen
Germany

T: +49 7161 206-0
M: info@kleemann.info

 www.kleemann.info