

Technical information

MINI 500



Tracked paver MINI 500

Mini Class

TECHNICAL HIGHLIGHTS

- > Pave widths 0.25 m - 1.8 m
- > Pave speed up to 2.4 km/h
- > Maximum laydown rate 20 tonnes/h
- > Transport width 0.9 m

MINI 500 - compact design, truly revolutionary

Conventional asphalt pavers are not especially suitable for projects with a pave width of less than 1.5 m - asphaltting cycle paths or ditches for pipelines/ fibre optic cables, for example. As a consequence, these projects are often completed manually, requiring at least four labourers. The result is frequently an uneven and relatively poor-quality surface course.

Our MINI 500 compact paver was designed to supply the market with a machine to make it easier for contractors to complete this type of project. Its manoeuvrability, compact size and low weight are outstanding.



TECHNICAL DATA	MINI 500
Antrieb	
Engine	
> Version	liquid-cooled 2-cylinder diesel engine
> Manufacturer	Kubota
> Type	Z602-E4B-EU-X7
Output	
> Nominal	10.2 kW at 3,200 rpm
> ECO mode	8 kW at 2,500 rpm
Emissions information	
> Exhaust emissions standards	EU Stage V, US EPA Tier 4f
> Guaranteed sound power level	$L_{WA} = 103 \text{ dB(A)}$ (2000/14/EG, EN ISO 3744; EN 500-6)
> Sound pressure level at the operator's stations	$L_{PA} \leq 85 \text{ dB(A)}$ (EN ISO 11201; EN 500-6)
Fuel tank	16 litres
Undercarriage	
Crawler tracks	
> Version	rubber-bonded steel tracks
> Ground contact	1,100 x 180 mm
> Track tension adjuster	spring assembly
> Lubrication of track rollers	lifetime
Traction drive	closed loop hydraulic system
Speeds	
> Paving	up to 40 m/min., infinitely variable
> Travel	up to 40 m/min., infinitely variable
Material hopper	
Hopper capacity	1.2 t
Width	1,245 x 2,050 mm (with hopper sides open)
Feed height	1,400 mm

Conveyors and auger

Conveyors

> Version	1, with wear-resistant steel conveyors with reversible running direction
> Drive	separate hydraulic drives
> Speed	17 m/min., infinitely variable

Augers

> Version	2, reversible auger rotation
> Diameter	140 mm
> Drive	separate hydraulic drives
> Option	
> Speed	94 rpm

Auger height 100 mm from the ground to the bottom edge of the augers

Screed options

Basic width	0.8 to 1.35 m
Maximum width	1.8 m
Minimum pave width	0.25 m
Compacting system	V
Layer thickness	up to 10 cm
Screed heating	
> Version	gas heating with 3 burners and electronic ignition
> Power supply	gas bottle

Dimensions (transport) and weights

Transport width	0.9 m
Length	
> Version	tractor unit with screed
> AB 135	2.6 m (with footstep folded away)
Weights	
> Version	tractor unit with screed
> AB 135	1,440 kg
> AB 135 with bolt-on extensions	1,464 kg

Key: AB = Extending Screed, V= with vibration

SIDE AND FRONT VIEW

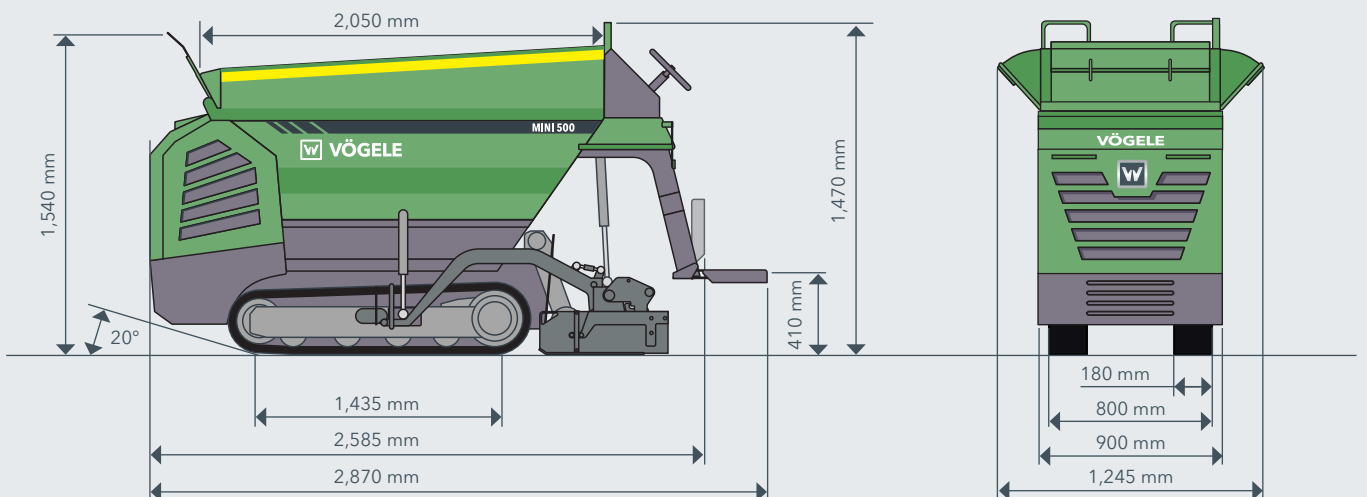

THE HIGHLIGHTS OF THE MINI 500

- > Water-cooled 2-cylinder diesel engine with an output of 10.2 kW ensures adequate drive power. Meets current EU Stage V exhaust emissions standards as well as EPA Tier 4.
- > Powerful hydrostatic drives efficiently apply the output of the diesel engine
- > The rubber tracks ensure optimum traction on loose sub-bases. Their extraordinary manoeuvrability means the tracked pavers can operate in an incredibly tight space.
- > Its material hopper with a capacity of 1.2 tonnes and the hopper sides allow the machine to be fed simply and conveniently by wheel loaders or excavators.
- > A conveyor made of wear-resistant steel transports the material to the sensor-controlled augers, which ensure a consistent head of material in front of the screed.
- > From the operator's standing position, a perfect overview is provided and the operator is able to conveniently handle the paver alone. The self-explanatory symbols and clear arrangement of the controls make MINI pavers very easy to operate.
- > Thanks to their compact dimensions, MINI pavers are ideal for construction projects involving the tightest of spaces, where a mechanical paving process would once have been inconceivable.
- > The AB 135 covers a broad range of paving applications. The minimum pave width with cut-off shoes is 25 cm, whilst maximum width with bolt-on extensions is 1.8 m. Compaction is effected by hydraulically controlled eccentric vibrators.
- > The screed is heated by liquid gas, with electronic ignition for maximum safety.

FEATURES	MINI 500
> Rubber-bonded steel tracks	■
> Hydraulic transmission system	■
> Electronic potentiometer for high-precision speed adjustment	■
> 40-amp alternator	■
> Gas-heated screed with hydraulically adjustable pave width: 800 - 1,350 mm	■
> Hydraulic vibrators with standby control	■
> Hydraulic system for checking layer thickness	■
> Automatic system for temperature control, electronic ignition	■
> Reducing system (minimum pave width: 25 cm)	□
> Separate augers and conveyors, driven by a single motor and two feed sensors	□
> System for Automated Grade and Slope Control with mount and 2 remote controls	□
> Remote control for the operator to adjust the screed	□

This list is just an extract of the scope of supply.
Standard features and options may differ by sales region.

■ Standard feature □ Option

JOSEPH VÖGELE AG

Joseph-Vögele-Str. 1
67075 Ludwigshafen
Germany

T: +49 621 8105-0
F: +49 621 8105-461
M: marketing@voegele.info

www.voegele.info

